



Australian Government
Australian Transport Safety Bureau

Collision between passenger train and truck

Woodvale, Victoria | 19 December 2014



Investigation

ATSB Transport Safety Report
Rail Occurrence Investigation
RO-2014-024
Final – 25 September 2015

Cover photo: Courtesy Victoria Police

This investigation was conducted under the Transport Safety Investigation Act 2003 (Cth) by the Chief Investigator, Transport Safety (Vic) on behalf of the Australian Transport Safety Bureau in accordance with the Collaboration Agreement entered into on 18 January 2013.

Released in accordance with section 25 of the *Transport Safety Investigation Act 2003*

Publishing information

Published by: Australian Transport Safety Bureau
Postal address: PO Box 967, Civic Square ACT 2608
Office: 62 Northbourne Avenue Canberra, Australian Capital Territory 2601
Telephone: 1800 020 616, from overseas +61 2 6257 4150 (24 hours)
Accident and incident notification: 1800 011 034 (24 hours)
Facsimile: 02 6247 3117, from overseas +61 2 6247 3117
Email: atsbinfo@atsb.gov.au
Internet: www.atsb.gov.au

© Commonwealth of Australia 2014



Ownership of intellectual property rights in this publication

Unless otherwise noted, copyright (and any other intellectual property rights, if any) in this publication is owned by the Commonwealth of Australia.

Creative Commons licence

With the exception of the Coat of Arms, ATSB logo, and photos and graphics in which a third party holds copyright, this publication is licensed under a Creative Commons Attribution 3.0 Australia licence.

Creative Commons Attribution 3.0 Australia Licence is a standard form license agreement that allows you to copy, distribute, transmit and adapt this publication provided that you attribute the work.

The ATSB's preference is that you attribute this publication (and any material sourced from it) using the following wording: *Source:* Australian Transport Safety Bureau

Copyright in material obtained from other agencies, private individuals or organisations, belongs to those agencies, individuals or organisations. Where you want to use their material you will need to contact them directly.

Addendum

Page	Change	Date

Safety summary

What happened

On 19 December 2014, a truck collided with the Swan Hill to Melbourne passenger train at a level crossing on Rileys Road, Woodvale, near Bendigo in central Victoria. Both occupants of the truck and one train passenger were conveyed to hospital with minor injuries. The truck sustained significant damage to its front, right-hand corner and there was significant side panel and underfloor damage to several passenger cars.

What the ATSB found

The ATSB found that the truck driver did not approach the level crossing with sufficient caution to be able to stop once he became aware of the approaching train. A road-user's view of an approaching train was partially obscured due to lineside vegetation.

What's been done as a result

V/Line Pty Ltd has:

- Advised that it has revised and strengthened vegetation control activities to maintain level crossing sight-lines.
- Initiated a discussion with the City of Greater Bendigo around a reduction of road speeds to 60 km/h on the approach to railway level crossings. This has resulted in the commencement of a trial program on gravel and sealed roads.
- Requested the Victorian Level Crossing Committee to upgrade the Rileys Road level crossing to active protection. This is scheduled for 2016-17, but may be delayed to 2017-18.

Safety message

This incident highlights the responsibility that rests upon road vehicle drivers to remain aware when approaching railway level crossings, especially those with passive protection. Road users who frequently use a level crossing that sees limited rail traffic should be alert to the potential of developing a sense of expectancy that trains will not be present. Drivers of heavy vehicles have a special responsibility to ensure they remain aware of the dangers of railway level crossings.

To ensure that road users can make a determination regarding crossing the track safely it is important that the track manager ensures that any lineside vegetation that might reduce the road-user's distant view of the track approaches be kept to an effective minimum.

Contents

The occurrence	1
Context	4
Truck	4
Train	4
Level crossing	4
Safety analysis	8
Collision scenario	8
Driver behaviour	8
Vehicle driver's view of approaching train	9
Management of lineside foliage	9
Findings	11
Contributing factors	11
Other factors that increased risk	11
Safety issues and actions	12
General details	14
Occurrence details	14
Train details	14
Sources and submissions	15
Sources of information	15
References	15
Submissions	15
Australian Transport Safety Bureau	16
Purpose of safety investigations	16
Developing safety action	16

The occurrence

At about 1445 on 19 December 2014, a truck was travelling east along Rileys Road in central Victoria—having just exited the Loddon Valley Highway—and was approaching a railway level crossing. The truck driver was accompanied by a family member.

The eastward road approach to the level crossing was across open farmland with good visibility of the railway in the right-hand direction. However, the view of a train approaching from the left (the Swan Hill direction) was partially obscured by trees within the rail reserve, until the train was about 200 m from the crossing

Train No 8042, had departed Swan Hill at 1250 and at 1445 was approaching the Rileys Road level crossing at the track speed of 100 km/h with the locomotive driver having observed the truck approaching from the right. The locomotive event recorder indicated that the driver sounded the locomotive warning horn at about 400 m from the level crossing, in a manner consistent with normal operating requirements, and then again for approximately 5 seconds commencing when the train was about 200 m from the crossing.

Around this time the truck driver commenced to brake heavily. The truck then continued, leaving a predominantly single-tyre skid mark along the gravel surface for about 85 m.

Figure 1: Location of incident

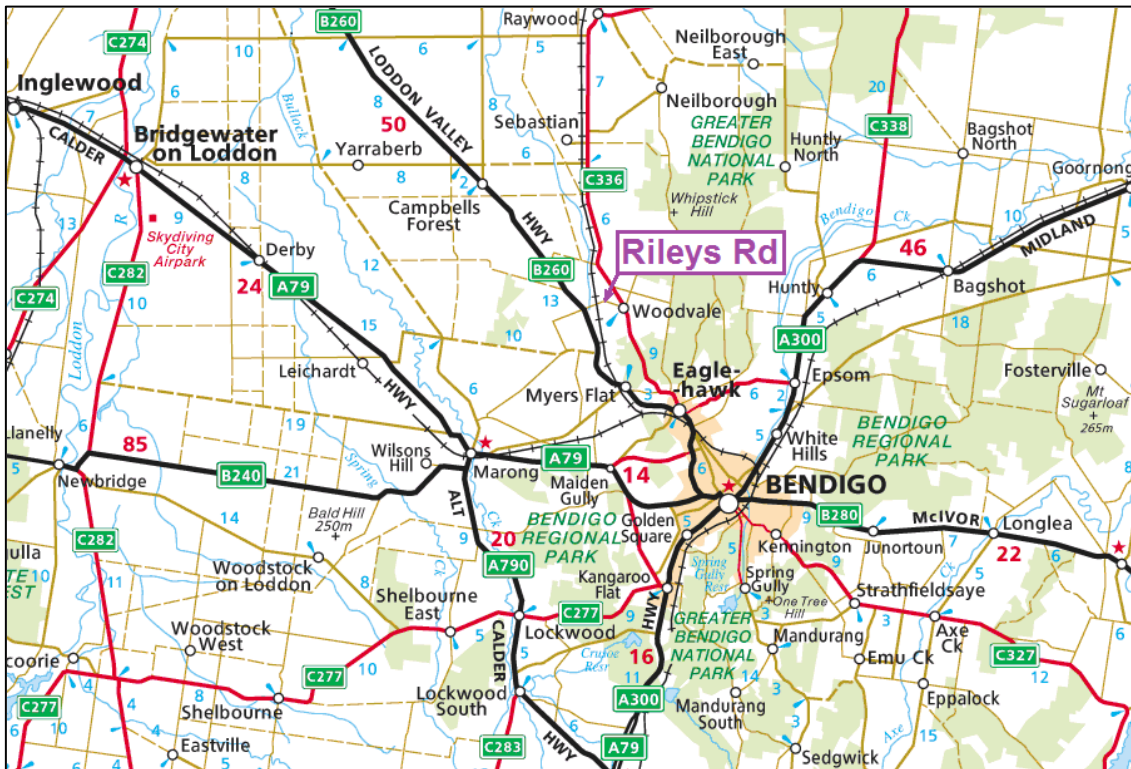

Source: Copyright, Google Maps. Annotated by Chief Investigator, Transport Safety (Vic)

Figure 2: The truck immediately after the collision



Source: Victoria Police

The truck was turned to the left—as the train occupied the crossing—and collided with the adjacent level crossing signage and the train.

This last-second avoidance manoeuvre by the truck driver presented the front right-hand corner of the truck’s cab to the train. As the train passed in front of it, this corner of the cab and the roo-bar struck the side of the first passenger car. This impact caused the derailment of that car’s trailing bogie, inflicted deep impact scars to its side panels (Figure 3) and tore through its exterior skin over approximately a two-metre length (Figure 4).

The impact also breached the underslung diesel generator fuel tank—precipitating an outflow of fuel—and destroyed some bogie-mounted brake equipment. The train consist then continued to scrape along the right-hand corner of the truck’s cab causing abrasion damage to the side panelling of most of the cars. The locomotive was not impacted. Track damage caused by the derailed passenger car required V/Line to replace approximately 200 sleepers.

The service was terminated – the passengers being conveyed by road coach for the remainder of their journey. One train passenger was hospitalised for observation and released the same day, and the truck driver and his passenger sustained minor injuries.

Figure 3: Damage sustained by the first car at the initial impact point



Source: Chief Investigator, Transport Safety (Vic)

Figure 4: Detail of intrusion into passenger car side panel – first car



Source: Chief Investigator, Transport Safety (Vic)

Context

Truck

The truck was a 4.5-tonne 1999-model Kenworth K-104 configured with a rigid, high-sided alloy tipping body used in the transportation of firewood. At the time of the incident it was travelling empty. The truck retained the branding of its previous owner.

The driver, who was correctly licensed, owned and operated the vehicle and was familiar with this crossing. The Preliminary Breath Test of the driver conducted at the scene by police returned a 'Negative' result.

Train

The train consisted of locomotive N457 and four passenger cars. It was 110 m in length, had a mass of approximately 304 tonnes, and was travelling at the authorised track speed. In addition to the locomotive driver, there were 74 passengers plus two on-board crew members and a services manager travelling as a supernumerary.

The locomotive was being operated within the limits of V/Line requirements, and the locomotive driver possessed the requisite health and route competency credentials. The driver did not realise, until his train had passed completely over the crossing, that it had been struck. When he became aware—from his rear-vision mirror—of a dust cloud rising from his train he made an Emergency air brake application and the train came to a stand 1100 m beyond the Rileys Road level crossing, and with its trailing end approximately 60 m past the next level crossing (Quinns Road).

Level crossing

Description

Rileys Road was a gravel-surfaced country road that intersected the railway at an angle of approximately 112 degrees to the left in the east-bound direction. This level crossing was approximately 700 m from the highway intersection. The crossing, which was protected by Give-Way signs, was situated on the V/Line Broad-Gauge network between Bendigo and Kerang, approximately 178 rail kilometres from Melbourne and 16 km from Bendigo Railway Station. The crossing is within the rail reserve leased by VicTrack to V/Line as part of intrastate rail network arrangements under which V/Line is responsible for maintenance of the reserve generally as well as for level crossings and for signage at crossings. Advance road warning signage is the responsibility of the applicable road authority, the City of Greater Bendigo. Rileys Road is approximately 2.1 km long and connects the Loddon Valley Highway with the Bendigo-Pyramid Road. The road did not have sign-posted speed limits and therefore carried the same 100 km/h speed limit applicable to the two major roads with which it intersects.

Signage

Control signage installed at the crossing was in good condition and included the Give-Way (RX-1) and width marker (RX-9) assemblies as stipulated in AS 1742.7 Manual of uniform traffic control devices, Part 7: Railway crossings.

Advance warning signage was in place on both road approaches. This signage consisted of the *Railway crossing ahead – Passive control sign W7-7* at 225 m from the level crossing, and the *Railway crossing diagrammatic warning assembly RX-3-1* at 174.5 m. These distances vary slightly from those specified in the Australian Standard.

Lineside vegetation

Several mature trees were growing near the railway fence line in the adjacent paddock to the north of Rileys Road, and a number of juvenile self-sown trees nearby were growing sporadically along a drainage ditch within the railway reserve. For the driver of a vehicle approaching the level crossing from the direction of the Loddon Valley Highway, this growth partially obscured from view a train approaching from the north until the train was about 200 m from the crossing.

Arboricultural advice was sought in relation to the trees growing in the rail reserve (Figure 5). The River Red Gum trees (*eucalyptus camaldulensis*) were in a group of around 40-50, growing in an area approximately 300 m long and 30 m wide. The stand of trees displayed height (1-9 m)¹ and 'breast-height'² trunk diameter characteristics consistent with ages of between 1 and 8 years. Situated along a drainage line subject to areas of seasonal standing water, the trees were judged to be in good condition and displaying vigorous growth. Expected growth rates of juvenile-to-young (1-15 years) River Red Gum growing in an ideal situation with good conditions is 1 to 1.5 m per year, and in most conditions the annual juvenile height growth rate will slow as the tree matures. If left standing, the trees in their current position can be expected to thrive and add good annual diameter and height.

Figure 5: Lineside tree growth. Arrows show direction of train



Source: Chief Investigator, Transport Safety (Vic)

There was also a clump of flowering acacia (a plant that grows to between 2 and 3 m in height over about 15 years) on the opposite side of the track and now at fence height. This vegetation is a potential future obstruction against a view of the track for vehicles approaching the crossing from the opposite direction (that is to say, from Bendigo-Pyramid Road towards the Loddon Valley Highway).

¹ The stated height of the trees includes the fact that most of them were growing in a ditch, from a position approximately 1.5 m below rail level.

² Diameter at Breast Height (DBH) is the diameter of a tree at approximately 1.4 m above ground level.

Figure 6: Aerial view of location - Rileys Road level crossing



Source: Image courtesy of Google Earth, annotated by Chief Investigator, Transport Safety (Vic)

Level crossing management of sighting

Australian Level Crossing Assessment Model (ALCAM) survey

ALCAM is the national model for assessing the vehicle safety risk at level crossings. Part of the assessment involves evaluating the required and actual sighting distances for road vehicles approaching the level crossing, with Australian Standard 1742.7 being used as the basis for this assessment. In Victoria, ALCAM crossing assessment and data collection is managed by VicTrack on behalf of Public Transport Victoria. As of the time of the incident, field assessments were being performed on a five-yearly basis. The most recent ALCAM assessment of the Rileys Road level crossing was conducted in October 2010.

Values for S1 and S2 (Figure 7) were evaluated as part of this ALCAM assessment. S1 is defined as the minimum distance of an approaching road vehicle from the nearest rail at which the driver of that road vehicle must be able to see an approaching train in time to stop if necessary before reaching the crossing. S2 is defined as the minimum distance of a train from the crossing at which a road vehicle driver at distance S1 from the crossing can proceed and safely clear the crossing ahead of the train.

Figure 7: Approach visibility at ‘Give-Way’ passive-control level crossing – Rileys Road

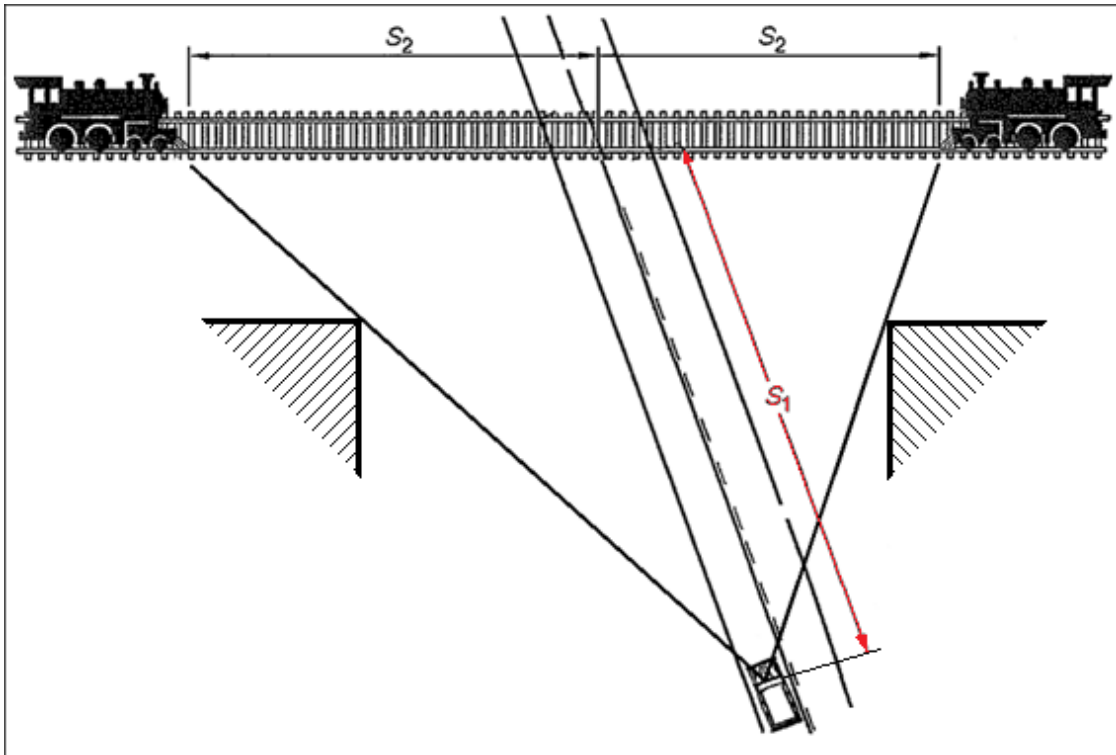

Source: AS 1742.7 *Manual of uniform traffic control devices, Part 7: Railway crossings*. Adapted by Chief Investigator, Transport Safety (Vic)

To evaluate sighting distances at the Rileys Road level crossing, the ALCAM assessment assumed a road vehicle approach speed³ of 70 km/h. For a train approaching from the North (from the vehicle driver's left – the train direction in this instance), the assessment provided a required S_2 value (left-hand side) of 240 m. A field survey measurement taken in 2010 indicated that the vehicle driver's view in this quadrant was unobstructed and this S_2 value satisfied.

Considering a normal growth rate of 1 to 1.5 m per year the taller of the self-seeded trees within the rail reserve would have been around 3 to 5 m (and therefore projecting from 1.5 to 3 m above rail level) when the last ALCAM survey was conducted in October 2010. The trees would most likely, therefore, not have presented as a sighting obstruction at that time.

Other sighting inspections

V/Line procedure NIPR-2714 Inspection and Assessment of Level Crossings provides guidance for the inspection and assessment of sight lines at level crossings. The procedure outlines the management and maintenance of sight distances in accordance with AS 1742.7 – 2007. The procedure also specifies the recording of obstructions that might restrict the road vehicle driver's view to the required sight distances.

Similar occurrence

This incident is similar to another⁴ involving a heavy vehicle being driven up to a railway level crossing, where the driver observed the approaching passenger train too late to avoid a collision. In this latter incident, the manner of the impact was similar except that the truck intruded completely into the side of several passenger carriages with resultant multiple fatalities.

³ The 85th percentile speed; the speed at or below which 85 per cent of vehicles are observed to travel on that road.

⁴ Chief Investigator, Transport and Marine Safety Investigations, Rail Safety Investigation Report № 2007/09: *Level Crossing Collision V/Line Passenger Train 8042 and a Truck near Kerang, Victoria, 5 June 2007*.

Safety analysis

Collision scenario

A number of potential truck speed and braking scenarios were considered based on the available evidence. It was estimated that the speed of the truck when braking commenced was probably around 80 km/h, assuming a deceleration distance of 85 m, a typical truck deceleration rate⁵, and a truck speed at the point-of-impact of 10 km/h. Other scenarios were also considered assuming a higher rate of deceleration and a truck speed at impact of 20 km/h. These resulted in estimations of initial truck speed in the 80-90 km/h range, this being within the speed limit for the road.

The reaction time for a vehicle driver upon perception of a threat is highly variable⁶ and the reaction time in this instance was probably between one and three seconds. For the purpose of estimating the position of the locomotive when the train first became apparent to the truck driver, the elapsed time from the train being perceived and the truck's brake application taking effect was assumed to be two seconds. This equates to the truck being approximately 130 m from the crossing when the train was first perceived, and the train being between 180 and 210 m from the crossing, considering a range of realistic scenarios.

Driver behaviour

Give-Way level crossing control places upon the road vehicle driver the responsibility to determine the presence of approaching rail traffic and to judge whether it is safe to proceed or whether to stop. The truck driver did not approach the level crossing with sufficient caution to be able to stop once he became aware of the approaching train.

Expectancy and familiarity

A study⁷ of drivers involved in accidents at passive level crossings discovered that a significant factor influencing road users to look for trains was their expectation of encountering one. An individual's perception of the probability of a particular event occurring is strongly influenced by past experience. The perception of road users that a train is unlikely to be present is reinforced every time they traverse the crossing and do not encounter a train. The study concludes that the frequency with which motorists encounter trains at level crossings will influence their likelihood of stopping at those crossings.

Another factor found to influence the behaviour of road users at a level crossing is their level of familiarity with that crossing⁸. A study involving passive level crossings⁹ determined that level crossing familiarity combined with the expectation that a train won't be present has the potential to lull road users into complacency.

The truck driver frequently used the local road but might have rarely encountered trains due to the relatively limited frequency of train movements on this line¹⁰. This may have resulted in him becoming desensitised to warning signage and developing poor scanning habits at this crossing.

⁵ AS1742.7

⁶ Olson P L., *Driver Perception Response Time*, The University of Michigan Transport Research Institute.

⁷ National Transportation Safety Board, Safety Study NTSB/SS-98/02, *Safety at passive grade crossing; Volume 1: Analysis*.

⁸ Yeh M. and Miltzer J. (2008), *Driver Behaviour at Highway-Railroad Grade Crossings: A Literature Review from 1990-2006. Human Factors in Railroad Operations*. United States Department of Transportation, Federal Railroad Administration.

⁹ Caird J.K., Creaser J.I., Edwards C.J., and Dewar R.E. - (2002), *Highway-Railway grade crossing research; A human factors analysis of highway-railway grade crossing accidents in Canada*; TP 13938E.

¹⁰ 28 passenger train movements per week (four per day) plus minimal infrequent grain train movements.

Vehicle driver's view of approaching train

Drivers of vehicles approaching the Rileys Road level crossing from the direction of the Loddon Valley Highway had a clear northerly view across an adjacent paddock toward the railway line, however the conspicuity of rail traffic approaching from that direction was diminished due to it being partially obscured by the merging of lineside foliage as viewed at an angle from the road (Figures 8 and 9).

Figure 8: Vehicle driver's field of view, through foliage, of the approaching train



Source: Google Earth, annotated by Chief Investigator, Transport Safety (Vic)

Figure 9: View of approaching train from the road 100 m back from the level crossing. Train is approximately 200 m from the crossing



Source: Chief Investigator, Transport Safety (Vic)

Management of lineside foliage

V/Line has a range of inspection regimes specific to rail corridors and level crossings to ensure that the corridor and the assets within them, such as track and level crossings, are 'safe and suitable for operations'. Sighting distances for passive level crossings are evaluated as part of an

annual assessment undertaken at each level crossing. These inspections, though, concentrate on readily-visible elements of infrastructure, and the issue of the management of vegetation growing within the rail reserve is not explicitly discussed in the context of the risk it might pose to a road user obtaining a clear view of approaching trains.

A Level Crossing Sighting Distance Inspection pro-forma is used to record details and report the current state of the crossing with respect to ALCAM sighting parameters. The Sighting Distance Inspection reports for 2012 and 2014 both noted that the S2 sighting distance met requirements and both reports noted the presence of foliage. In neither case were these comments expanded-upon, nor any specific remedial suggestions provided. In neither case also, was there an identified requirement to clear foliage from within sight lines.

The ATSB inspection at the date of this incident identified that sight lines in the relevant direction were 40 m less than the required 240 as specified in the ALCAM assessment and used by V/Line. In October 2010, though—when the most recent ALCAM survey of the Rileys Road level crossing was completed—the string of River Red Gum trees along the lineside ditch would not have been as high and would probably not have presented as a sighting obstruction.

Findings

From the evidence available, the following findings are made with respect to the level crossing collision that occurred on Rileys Road, Woodvale, 16 km north of Bendigo, Victoria, on 19 December 2014. These findings should not be read as apportioning blame or liability to any particular organisation or individual.

Safety issues, or system problems, are highlighted in bold to emphasise their importance.

A safety issue is an event or condition that increases safety risk and (a) can reasonably be regarded as having the potential to adversely affect the safety of future operations, and (b) is a characteristic of an organisation or a system, rather than a characteristic of a specific individual, or characteristic of an operating environment at a specific point in time.

Contributing factors

- The truck driver did not approach the level crossing with sufficient caution to be able to stop once he became aware of the approaching train.

Other factors that increased risk

- A line of self-sown trees of varying heights were growing within the railway reserve. When viewed at an angle from the road this growth partially concealed the presence of an approaching train.
- V/Line's process for the inspection of level crossing sighting did not provide explicit instructions for the identification and removal of problem vegetation. [Safety issue]

Safety issues and actions

Depending on the level of risk of the safety issue, the extent of corrective action taken by the relevant organisation, or the desirability of directing a broad safety message to the rail industry, the ATSB may issue safety recommendations or safety advisory notices as part of the final report.

The safety issues identified during this investigation are listed in the Findings and Safety issues and actions sections of this report. The Australian Transport Safety Bureau (ATSB) expects that all safety issues identified by the investigation should be addressed by the relevant organisation(s). In addressing those issues, the ATSB prefers to encourage relevant organisation(s) to proactively initiate safety action, rather than to issue formal safety recommendations or safety advisory notices.

Management of lineside foliage

Number:	RO-2014-024-SI-01
Issue owner:	V/Line
Operation affected:	Rail operations
Who it affects:	All road users and operators of trains on trackage owner or managed by V/Line.

Safety issue description:

V/Line's process for the inspection of level crossing sighting did not provide explicit instructions for the identification and removal of problem vegetation.

Response to safety issue and/or proactive safety action taken by V/Line.

Action number: RO-2014-024-NSA-020

V/Line Pty Ltd has advised that it has reviewed its Asset Management Framework to include elements of vegetation control that are more explicit than currently exist, and is proceeding as follows:

- Is engaging the services of a vegetation management contractor to undertake hazardous tree assessment—including of predicted growth—that could impact rail, staff, or customer and neighbour safety.
- Has revised the inspection frequency for Level Crossing Line-of-Sight inspections from an annual requirement to a 3-monthly inspection via a foot patrol.
- Is revising the vegetation/hazardous trees inspection from annually to monthly via a foot patrol.
- Is instigating a Plan-Do-Review (PDR) cycle that is expected to improve the management of faults identified from inspections. The outcomes are expected to be implemented by 1st July 2015. This includes the inspections outlined above for Level Crossing Line-of-Sight and Hazardous Trees/Vegetation Management.
- Is introducing weekly PDR meetings after every set of inspections, and developing a rolling 4-weekly corridor-by-corridor plan.

Current status of the safety issue

Issue status: Closed.

Justification: The ATSB is satisfied that the actions proposed by V/Line Pty Ltd will, when fully implemented, adequately address this safety issue.

Other safety actions

V/Line has also advised that it has:

- Initiated a discussion with the City of Greater Bendigo on the subject of a reduction to 60 km/h of road speed on the approach to railway level crossings. This has resulted in the commencement of a trial program on both gravel and sealed roads.
- Requested the Victorian Level Crossing Committee to upgrade the Rileys Road level crossing to active protection. This is scheduled for 2016-17, but may be delayed to 2017-18
- Cleared trees and vegetation from the rail reserve.

General details

Occurrence details

Date and time:	19 December 2014 – 1450 EST	
Occurrence category:	Serious incident	
Primary occurrence type:	Level crossing collision	
Location:	Rileys Rd, Woodvale, near Bendigo, Victoria	
	Latitude: 36° 40.057' S	Longitude: 144° 12.285' E

Train details

Train operator:	V/Line Pty Ltd	
Registration:	TD 8042	
Type of operation:	Passenger rail	
Persons on board:	Crew – 4	Passengers – 73
Injuries:	Crew – None	Passengers – 1 (minor)
Damage:	Substantial to train	

Sources and submissions

Sources of information

The sources of information during the investigation included:

- V/Line Pty Ltd
- Victoria Police.

References

Olson P L., *Driver Perception Response Time*, University of Michigan Transport Research Institute.

National Transportation Safety Board, Safety Study NTSB/SS-98/02, *Safety at passive grade crossing; Volume1: Analysis*.

Yeh M. and Miltzer J. (2008), *Driver Behaviour at Highway-Railroad Grade Crossings: A Literature Review from 1990-2006. Human Factors in Railroad Operations*. United States Department of Transportation, Federal Railroad Administration.

Caird J.K., Creaser J.I., Edwards C.J., and Dewar R.E. (2002), *Highway-Railway grade crossing research; A human factors analysis of highway-railway grade crossing accidents in Canada*; TP 13938E.

V/Line procedure; NIPR-2606 *Management of Inspection Outcomes* (17/10/13, Rev 7).

V/Line procedure; NIPR-2714 *Inspection and Assessment of Level Crossings* (09/11/2010, v4).

V/Line pro-forma; NIFO-2714.4 *Level Crossing Sighting Distance Inspection*.

Chief Investigator, Transport and Marine Safety Investigations, Rail Safety Investigation Report No 2007/09: *Level Crossing Collision V/Line Passenger Train 8042 and a Truck near Kerang, Victoria, 5 June 2007*.

Submissions

Under Part 4, Division 2 (Investigation Reports), Section 26 of the *Transport Safety Investigation Act 2003* (the Act), the Australian Transport Safety Bureau (ATSB) may provide a draft report, on a confidential basis, to any person whom the ATSB considers appropriate. Section 26 (1) (a) of the Act allows a person receiving a draft report to make submissions to the ATSB about the draft report.

A draft of this report was provided to V/Line Pty Ltd, Victoria Police, and the truck driver. Submissions from these parties were reviewed and where considered appropriate, the text of the draft report was amended accordingly.

Australian Transport Safety Bureau

The Australian Transport Safety Bureau (ATSB) is an independent Commonwealth Government statutory agency. The ATSB is governed by a Commission and is entirely separate from transport regulators, policy makers and service providers. The ATSB's function is to improve safety and public confidence in the aviation, marine and rail modes of transport through excellence in: independent investigation of transport accidents and other safety occurrences; safety data recording, analysis and research; fostering safety awareness, knowledge and action.

The ATSB is responsible for investigating accidents and other transport safety matters involving civil aviation, marine and rail operations in Australia that fall within Commonwealth jurisdiction, as well as participating in overseas investigations involving Australian registered aircraft and ships. A primary concern is the safety of commercial transport, with particular regard to fare-paying passenger operations.

The ATSB performs its functions in accordance with the provisions of the *Transport Safety Investigation Act 2003* and Regulations and, where applicable, relevant international agreements.

Purpose of safety investigations

The object of a safety investigation is to identify and reduce safety-related risk. ATSB investigations determine and communicate the factors related to the transport safety matter being investigated.

It is not a function of the ATSB to apportion blame or determine liability. At the same time, an investigation report must include factual material of sufficient weight to support the analysis and findings. At all times the ATSB endeavours to balance the use of material that could imply adverse comment with the need to properly explain what happened, and why, in a fair and unbiased manner.

Developing safety action

Central to the ATSB's investigation of transport safety matters is the early identification of safety issues in the transport environment. The ATSB prefers to encourage the relevant organisation(s) to initiate proactive safety action that addresses safety issues. Nevertheless, the ATSB may use its power to make a formal safety recommendation either during or at the end of an investigation, depending on the level of risk associated with a safety issue and the extent of corrective action undertaken by the relevant organisation.

When safety recommendations are issued, they focus on clearly describing the safety issue of concern, rather than providing instructions or opinions on a preferred method of corrective action. As with equivalent overseas organisations, the ATSB has no power to enforce the implementation of its recommendations. It is a matter for the body to which an ATSB recommendation is directed to assess the costs and benefits of any particular means of addressing a safety issue.

When the ATSB issues a safety recommendation to a person, organisation or agency, they must provide a written response within 90 days. That response must indicate whether they accept the recommendation, any reasons for not accepting part or all of the recommendation, and details of any proposed safety action to give effect to the recommendation.

The ATSB can also issue safety advisory notices suggesting that an organisation or an industry sector consider a safety issue and take action where it believes it appropriate. There is no requirement for a formal response to an advisory notice, although the ATSB will publish any response it receives.

Investigation

ATSB Transport Safety Report Rail Occurrence Investigation

Collision between passenger train and truck
Woodvale, Victoria, 19 December 2014

RO-2014-024

Final – 25 September 2015

Australian Transport Safety Bureau

Enquiries 1800 020 616

Notifications 1800 011 034

REPCON 1800 011 034

Web www.atsb.gov.au

Twitter @ATSBinfo

Email atsbinfo@atsb.gov.au