

Appendices

Appendix A – Water and Sewer Demand Basis

Design Basis Assumptions

Residential and Employment Demands

1. Residential	Base Case	Alternative Cases
----------------	-----------	-------------------

Average Demands

Ave day demand (L/person/day)	Total	192.7	192.7
-------------------------------	-------	-------	-------

Adopted SEW Draft Design Basis Value.

End Use Distribution

End Use Distribution			
* See below for additional cooling tower demand	Dishwasher	1%	1%
	Misc (incl. tap)	13%	13%
	Shower (& bath tub)	37%	37%
	Leak (potable)	8%	5%
	Leak (RW)		3%
	Clotheswasher	19%	19%
	Toilet	18%	18%
	Outdoor / Gardening	4%	4%

Adopted end-use proportions used for Western Region projects, as these are based on analysis of end-use studies by CWW.

Average Cooling Tower Demand (Additional demand for future sensitivity testing - not included in current average/peak demands)

Ave day demand (L/m2/day) (buildings with cooling towers)	Cooling Tower	2.19	2.19
Floor space to population ratio (m2 per person)	m2 per person	50	50
Ave day demand (L/person/day) (buildings with cooling towers)	Cooling Tower	110	110
Uptake (% of buildings)	Cooling Tower	25%	25%
Ave day demand (L/person/day) (averaged across all buildings)	Cooling Tower	27	27

Source: City of Sydney Benchmark 0.8 kL/m2/yr

Source: Guess

End uses supplied by dual pipe / recycled water

Supplied By RW		0	1
	Leak (RW)	0	1
	Clotheswasher	0	1
	Toilet	0	1
	Outdoor / Gardening	0	1

0 = Potable supply

1 = Recycled water supply

Average Demand Summary

Ave day (L/person/day)	Potable	193	108
	Recycled Water	0	85

Peaking Factors

Ave Day to Peak Day	Potable	1.49	1.49
	Recycled Water		1.5
Peak Day to Peak Hour	Potable	2.5	2.24
	Recycled Water		1.67

Base Case peaking factors

Peak Demands

Peak Day (L/person/day)	Potable	287	161
	Recycled Water	0	126
Peak Hour (L/person/second)	Potable	0.0084	0.0042
	Recycled Water	0	0.0024

Wastewater Generation

End uses to sewer	L/person/day	175	175
-------------------	--------------	-----	-----

Total ave demand minus 100% outdoor, 100% cooling, 50% leaks, 10% of taps (OLV Guidelines)

2. Employment	Base Case	Alternative Cases
---------------	-----------	-------------------

Ave day (L/person/day)	Total	95	95
------------------------	-------	----	----

SEW/AECOM value adopted.

End Use Distribution

End Use Distribution	Other non-potable		
* See below for additional cooling tower demand	Shower	2%	2%
	Potable	30%	30%
	Other Non-Domestic	7%	7%
	Fire System	3%	3%
	Toilet	49%	49%
	Irrigation	9%	9%
	Clotheswashing		

CWW assumptions provide clearest breakdown of end uses for commercial demand.

Currently the cooling tower is assumed to be only 4% (not 34%), so everything else is scaled up accordingly.

Ave day (L/m2/day) (buildings with cooling towers)	Cooling Tower	2.19	2.19
Floor space to population ratio (m2 per person)	m2 per person	20	20
Ave day (L/person/day) (buildings with cooling towers)	Cooling Tower	44	44
Uptake (% of buildings)	Cooling Tower	50%	50%
Ave day (L/person/day) (averaged across all buildings)	Cooling Tower	22	22

Source: City of Sydney Benchmark 0.8 kL/m2/yr

Source: Assumed average.

Supplied By RW	Toilet	0	1
	Irrigation	0	1
	Clotheswashing	0	0

0 = Potable supply

1 = Recycled water supply

Ave day (L/person/day)	Potable	95	40
	Recycled Water	0	55

Ave Day to Peak Day	Potable	1.4	1.4
	Recycled Water		1.4
Peak Day to Peak Hour	Potable	2.2	2.01
	Recycled Water		1.58

SEW/AECOM (Inner

Peak Day (L/person/day)	Potable	133	56
	Recycled Water	0	77
Peak Hour (L/person/second)	Potable	0.0034	0.0013
	Recycled Water	0	0.0014

Total demand minus 100% outdoor/gardening, 100% cooling towers, 50% leaks, 10% taps (OLV Guidelines)

End uses to sewer	L/person/day	86	86
-------------------	--------------	----	----

Public open space demand

1. Estimated irrigation requirements

Demand	Unit	Elite Turf	Premium Turf	Local Turf	Passive Turf
Average annual	ML/ha/yr	5.5	2.2	1.6	1.0
January 50th %ile	ML/ha/mth	1.1	0.5	0.4	0.3
January 100th %ile (peak month)	ML/ha/mth	1.6	1.0	0.8	0.7
	mm/ha/d	5.29	3.17	2.63	2.10
Average day (in peak month)	L/ha/s	0.61	0.37	0.30	0.24

Demands derived by GHD using a monthly irrigation model. The model, based on SA Water's *Code of Practice: Irrigated Public Open Space (IPOS)* and *FAO Paper 56*, uses monthly evapotranspiration and rainfall data to calculate the theoretical crop water requirement to achieve a desired turf/vegetation quality (i.e. the unrestricted demand for irrigation water). These turf/vegetation qualities are specified for different types of open space (e.g. active, passive, streetscapes, etc.).

Results are shown as the average or percentiles over the period 1900 - 2013.

Assumptions:

Weather Station = Melbourne Regional Office (86071)

Ea (%) = 80%

AWHC (mm/m) = 60

Climata data source: SILO (daily patched point data from 1900 to 2013)

2. Peak irrigation rates

Ave Day to Max Day (in Peak Month)	1.2
Ave Day to Max Hour (in Peak Month)	3.0

	Irrigated Open Space	Turf Category (IPOS TQVS)	Average day demand (mm/ha/day)	Peak day demand (mm/ha/day)	Peak hour demand (mm/ha/day)
Demands (in Peak Month of January)	Active Open Space	Elite Turf	5.3	6.3	15.9
	Passive Open Space	Local Turf	2.6	3.2	7.9
	Streetscapes *	Passive Turf	2.1	2.5	6.3

* Inclusive of street trees

Population

1. Total Population

Total Population	Design Basis	Sensitivities	
	Ultimate Development	Low (-50%)	High (+50%)
Residential	120,000	80,000	180,000
Employment	61,050	40,700	91,575

Source:

SFP states 80,00 residents and 40,700 employment population (17,700 current + 23,000 additional)

MPA dwelling projections are 60,000 for ultimate development (assumed to be equal 120,000 population at 2.0 people per dwelling), noting that the dwelling count for the year 2050/51 appears to correspond with the residential population stated in the SFP.

2. Precinct Population

Residential Population by Precinct	Design Basis	Sensitivities		Res Distribution *
	Ultimate Development	Low (-50%)	High (+50%)	
Lorimer Precinct	20,000	13,333	30,000	17%
Montague Precinct	30,000	20,000	45,000	25%
Sandridge Precinct	40,000	26,667	60,000	33%
Wirraway Precinct	30,000	20,000	45,000	25%
Total	120,000	80,000	180,000	

* MPA dwelling projections broken down by precinct.

Employment Population by Precinct	Design Basis	Sensitivities		Emp Distribution **
	Ultimate Development	Low (-50%)	High (+50%)	
Lorimer Precinct	7,308	4,872	10,963	12%
Montague Precinct	11,435	7,623	17,152	19%
Sandridge Precinct	30,622	20,415	45,934	50%
Wirraway Precinct	11,684	7,790	17,527	19%
Total	61,050	40,700	91,575	

** Places Victoria floor space data for the Integrated Infrastructure Plan

3. Population disaggregation to local/polygon scale

Method:

1. Distribute precinct population based on area.

2. Scaling applied based on development height (e.g. twice as many people allocated to 12 storey than 6 storey).

Scaling factors	Residential	Commercial
12 storey discretionary (40)	40%	40%
18 storey discretionary (60m)	60%	60%
30 storey discretionary (100m)	100%	100%
4 storey discretionary (15m)	15%	15%
6 storey discretionary (20m)	20%	20%
6m Setback	0	0
8 storey discretionary (27m)	27%	27%
Discretionary	150%	150%
Existing Open Space	0	0
Green Link	0	0
Proposed Local Recreational Open Space	0	0
Proposed Neighbourhood Open Space	0	0
Roads	0	0
Proposed Road	0	0

Land Use

1. Impervious fractions / surface type assumptions for each mapped land use

		3	4	5	6	7	8	9	10		
		Irrigated Pervious		Other Pervious	Impervious					Total	Impervious
Scaling factors		Active Open Space	Passive Open Space	Streetscapes	Other	Road	Pavements	Roof	Platform		
12 storey discretionary (40)	BUILDING	0%	0%	0%	0%	0%		100%	0%	100%	100%
12 storey discretionary (40)	PLATFORM	0%	50%	0%	0%	0%		0%	50%	100%	50%
18 storey discretionary (60m)	BUILDING	0%	0%	0%	0%	0%		100%	0%	100%	100%
18 storey discretionary (60m)	PLATFORM	0%	50%	0%	0%	0%		0%	50%	100%	50%
30 storey discretionary (100m)	BUILDING	0%	0%	0%	0%	0%		100%	0%	100%	100%
30 storey discretionary (100m)	PLATFORM	0%	50%	0%	0%	0%		0%	50%	100%	50%
4 storey discretionary (15m)	BUILDING	0%	0%	0%	0%	0%		100%	0%	100%	100%
6 storey discretionary (20m)	BUILDING	0%	0%	0%	0%	0%		100%	0%	100%	100%
6m Setback	(blank)	0%	0%	100%	0%	0%		0%	0%	100%	0%
8 storey discretionary (27m)	BUILDING	0%	0%	0%	0%	0%		100%	0%	100%	100%
8 storey discretionary (27m)	PLATFORM	0%	50%	0%	0%	0%		0%	50%	100%	50%
Discretionary	BUILDING	0%	0%	0%	0%	0%		100%	0%	100%	100%
Discretionary	PLATFORM	0%	50%	0%	0%	0%		0%	50%	100%	50%
Existing Open Space	(blank)	60%	20%	0%	0%	0%		20%	0%	100%	20%
Green Link	(blank)	0%	0%	50%	0%	0%	50%	0%	0%	100%	50%
LANEWAY	(blank)	0%	0%	0%	0%	0%	100%	0%	0%	100%	100%
Proposed Local Recreational Open Space	(blank)	60%	20%	0%	0%	0%		20%	0%	100%	20%
Proposed Neighbourhood Open Space	(blank)	0%	80%	0%	0%	0%	20%	0%	0%	100%	20%
Roads		0%	0%	20%	0%	60%	20%	0%	0%	100%	80%

Note: The Green link land use category has been mapped as a 6m linear park adjacent to the "Green link roads"

2 Exported Land Use from Base Map

Land Use Category		Land Area (m2)				Total (m2)	Total (ha)
		Lorimer Precinct	Montague Precinct	Sandridge Precinct	Wirraway Precinct		
12 storey discretionary (40)	BUILDING			24338	50269	74,606	7
12 storey discretionary (40)	PLATFORM			27228	39469	66,697	7
18 storey discretionary (60m)	BUILDING		9892			9,892	1
18 storey discretionary (60m)	PLATFORM		9956			9,956	1
30 storey discretionary (100m)	BUILDING		20525			20,525	2
30 storey discretionary (100m)	PLATFORM		21156			21,156	2
4 storey discretionary (15m)	BUILDING		33179	118839	87123	239,141	24
6 storey discretionary (20m)	BUILDING	5699				5,699	1
6m Setback	(blank)		2230	11938	13887	28,056	3
8 storey discretionary (27m)	BUILDING		27172			27,172	3
8 storey discretionary (27m)	PLATFORM		26902			26,902	3
Discretionary	BUILDING	69233	52984	131842	114024	368,083	37
Discretionary	PLATFORM	70310	52633	133858	95802	352,604	35
Existing Open Space	(blank)			34190	194797	228,988	23
Green Link	(blank)		8001	13820	6807	28,629	3
LANEWAY	(blank)	14204	16805	54662	47698	133,369	13
Proposed Local Recreational Open Space	(blank)	28961	6303	25935	41632	102,832	10
Proposed Neighbourhood Open Space	(blank)	30000		26944	29995	86,939	9
Roads		55405	145514	273857	258930	733,705	73
Total Area		273,812	433,255	877,451	980,434	2,564,952	256

Source: Digitised from Strategic Framework Plan High Res PDFs

3. Impervious area totals

		Impervious Area (m2)				Total (m2)	Total (ha)
		Lorimer Precinct	Montague Precinct	Sandridge Precinct	Wirraway Precinct		
Impervious Area	Road	33,243	87,308	164,314	155,358	440,223	44
	Pavements	31,285	49,908	121,732	108,887	311,813	31
	Roof	80,724	145,014	287,043	298,702	811,483	81
	Platform	35,155	55,324	80,543	67,635	238,658	24
	Total	180,408	337,555	653,633	630,581	1,802,177	180
Impervious Fraction		66%	78%	74%	64%	70%	

4. Irrigated area totals

		Irrigated Area (ha)				Total (ha)
		Lorimer Precinct	Montague Precinct	Sandridge Precinct	Wirraway Precinct	
Irrigated Pervious	Active Open Space	2	0	4	14	20
	Passive Open Space	6	6	11	14	37
	Streetscapes	1	4	7	7	19

Water Quality Parameters

Wastewater contaminant concentrations

	N kg/ML	P kg/ML	TSS kg/ML
Wastewater	50	10	150
Wastewater Discharged at WTP	15	10	30

Stormwater quality management objectives

	N % reduction required	P % reduction required	TSS % reduction required
BPBM	45%	45%	80%
New BPBM	50%	50%	85%

Rainfall

639 mm, long term average annual rainfall

[1] Melbourne Regional Office 86071. LTA average from 1900-2013.

[2] 10th %ile and 90th %ile annual rainfall are 467 mm and 826 mm respectively (-27% and +29% relative to 50th %ile)

Water Balance Summary

Water Demand

Annual averages

	Unit Demand		Average Annual Demand for Fishermans Bend			
			Design Basis	Sensitivities		
				Ultimate Development	Low (-50%)	
Residential	193	L/person/day	8,440	5,627	12,660	ML/yr
Commercial	95	L/person/day	2,117	1,411	3,175	ML/yr
Open Space			188	188	188	ML/yr
Active Open Space	5.5	ML/ha/yr	110	110	110	ML/yr
Passive Open Space	1.6	ML/ha/yr	59	59	59	ML/yr
Streetscapes	1.0	ML/ha/yr	19	19	19	ML/yr
Total			10,745	7,226	16,024	ML/yr

Summary by precinct

Average Demand	Lorimer Precinct	Montague Precinct	Sandridge Precinct	Wirraway Precinct	Total	
Residential	1,407	2,110	2,813	2,110	8,440	ML/yr
Commercial	253	396	1,062	405	2,117	ML/yr
Open Space	21	15	45	107	188	ML/yr
Total	1,681	2,521	3,921	2,622	10,745	ML/yr

Summary by potable / substitutable

Average Demand	Potable	Substitutable	Total	
Residential	4,728	3,712	8,440	ML/yr
Commercial	896	1,221	2,117	ML/yr
Open Space	0	188	188	ML/yr
Total	5,624	5,121	10,745	ML/yr

Stormwater quality management objectives

	N kg/ML	P kg/ML	TSS kg/ML
Stormwater runoff (pre-treatment)			
Road	2.2	0.5	270
Pavements	2	0.25	140
Roof	2	0.13	20
Platform	2	0.13	20
BPBM			
Road	1.2	0.28	54.0
Pavements	1.1	0.14	28
Roof	1.1	0.07	4
Platform	1.1	0.07	4
New BPBM (not used in this pollutant balance)			
Road	1.1	0.25	40.5
Pavements	1.0	0.13	21.0
Roof	1.0	0.07	3.0
Platform	1.0	0.07	3

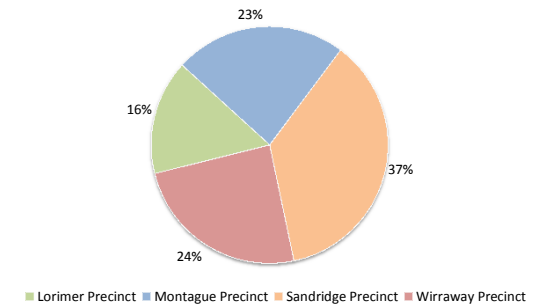
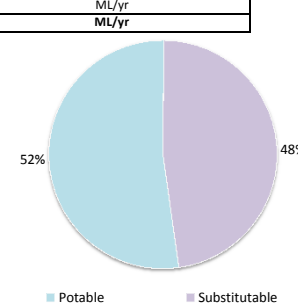
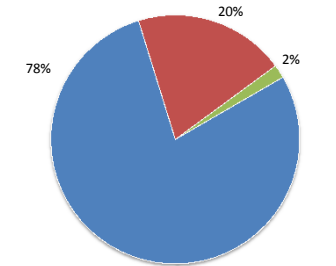

Wastewater Generation

	ADWF Per Capita		Average Dry Weather Flow for Fishermans Bend			
			Design Basis	Sensitivities		
	Ultimate Development	Low (-50%)	High (+50%)			
Residential	175	L/person/day	7,663	5,109	11,495	ML/yr
Commercial	86	L/person/day	1,909	1,273	2,864	ML/yr
Total			9,573	6,382	14,359	ML/yr

Stormwater Runoff

Stormwater runoff from impervious surfaces (ML/yr)	Stormwater	Montague Precinct	Sandridge Precinct	Wirraway Precinct	Total	
	Road	21	56	105	99	281
Pavements	20	32	78	70	199	ML/yr
Roof	52	93	183	191	519	ML/yr
Platform	22	35	51	43	153	ML/yr
Total	115	216	418	403	1,152	ML/yr

Pollutants

Stormwater		N	P	TSS	
Stormwater runoff	Road	619	141	75,952	kg/yr
	Pavements	398	50	27,895	kg/yr
	Roof	1,037	67	10,371	kg/yr
	Platform	305	20	3,050	kg/yr
	Total	2,359	278	117,267	kg/yr
Stormwater discharge to environment (from WSUD to meet BPEM)	Road	340	77	15,190	kg/yr
	Pavements	219	27	5,579	kg/yr
	Roof	570	37	2,074	kg/yr
	Platform	168	11	610	kg/yr
Total	1,298	153	23,453	kg/yr	
Stormwater discharge to environment (from WSUD & Stormwater harvesting - beyond BPEM)	Option 0	886	126	21,957	kg/yr
	Option 1	886	126	21,957	kg/yr
	Option 2	886	126	21,957	kg/yr
	Option 3	744	101	17,049	kg/yr
	Option 4	752	101	17,003	kg/yr
	Option 5	816	114	19,720	kg/yr
Wastewater		N	P	TSS	
Raw Wastewater		478,634	95,727	1,435,901	kg/yr
Treated Wastewater (WTP)		143,590	95,727	287,180	kg/yr
Combined		N	P	TSS	
Stormwater runoff		2.4	0.3	117.3	tonnes/yr
Raw wastewater		479	96	1,436	tonnes/yr
Stormwater discharge (post WSUD)		1.3	0.2	23.5	tonnes/yr
Stormwater discharge (post WSUD & Rainwater/Stormwater Harvesting) - Highest Load (Option 0)		0.9	0.1	22.0	tonnes/yr
Wastewater discharge (at WTP) - Highest Load (Option 0)		144	96	287	tonnes/yr

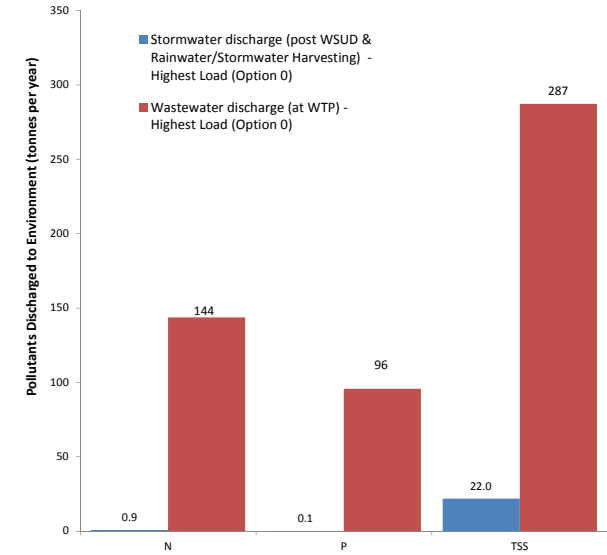

Historical Rainfall Record

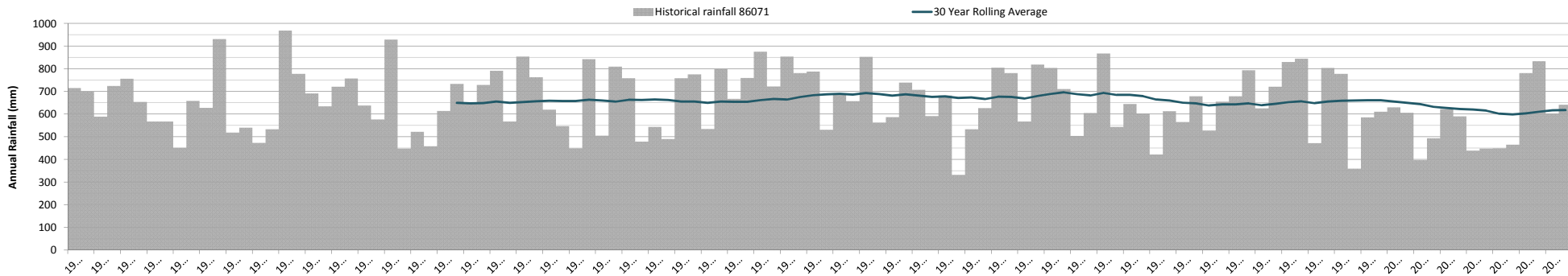

Potable water demand summary (refer for Water Modelling)

1. Peak Day Demand Summary

	Unit Demand		Peak Day Demand for Fishermans Bend			
			Design Basis	Sensitivities		
			Ultimate Development	Low (-50%)	High (+50%)	
Residential	287	L/person/day	399	266	598	
Commercial	133	L/person/day	94	63	141	L/s
Open Space			34	34	34	L/s
Active Open Space	6.3	mm/ha/day	15	15	15	L/s
Passive Open Space	3.2	mm/ha/day	14	14	14	L/s
Streetscapes	2.5	mm/ha/day	6	6	6	L/s
Total			527	362	773	L/s

2 Peak Day Demand by Precinct

Design Basis (Ultimate Development)	Peak Day Demand (L/s)	Lorimer Precinct	Montague Precinct	Sandridge Precinct	Wirraway Precinct	Total
	Residential	66	100	133	100	399
	Commercial	11	18	47	18	94
	Open Space	4	3	9	18	34
	Total	82	121	189	135	527
Sensitivity (Low)	Peak Day Demand (L/s)	Lorimer Precinct	Montague Precinct	Sandridge Precinct	Wirraway Precinct	Total
	Residential	44	66	89	66	266
	Commercial	8	12	31	12	63
	Open Space	4	3	9	18	34
	Total	56	82	129	96	362
Sensitivity (High)	Peak Day Demand (L/s)	Lorimer Precinct	Montague Precinct	Sandridge Precinct	Wirraway Precinct	Total
	Residential	100	150	199	150	598
	Commercial	17	26	71	27	141
	Open Space	4	3	9	18	34
	Total	121	179	279	194	773

Wastewater generation summary (refer for Sewer Modelling)

1. Summary

	ADWF Per Capita		Average Dry Weather Flow for Fishermans Bend			
			Design Basis	Sensitivities		
			Ultimate Development	Low (-50%)	High (+50%)	
Residential	175	L/person/day	243	162	365	
Commercial	86	L/person/day	61	40	91	L/s
Total			304	202	455	L/s

2 By Precinct

Design Basis (Ultimate Development)	ADWF (L/s)	Lorimer Precinct	Montague Precinct	Sandridge Precinct	Wirraway Precinct	Total
	Residential	41	61	81	61	243
	Commercial	7	11	30	12	61
	Total	48	72	111	72	304
Sensitivity (Low)	ADWF (L/s)	Lorimer Precinct	Montague Precinct	Sandridge Precinct	Wirraway Precinct	Total
	Residential	27	41	54	41	162
	Commercial	5	8	20	8	40
	Total	32	48	74	48	202
Sensitivity (High)	ADWF (L/s)	Lorimer Precinct	Montague Precinct	Sandridge Precinct	Wirraway Precinct	Total
	Residential	61	91	122	91	365
	Commercial	11	17	46	17	91
	Total	72	108	167	109	455

Appendix B – Existing Infrastructure Plans

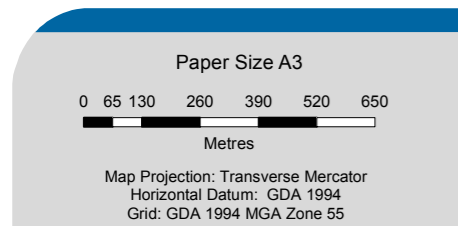

LEGEND			
	Precinct Boundaries		Highway
	Tramway		Arterial
	Railway		Collector
	Freeway		Proposed
	Tramway		Ferry
	Watercourse		Reserve
	Lake		Sport facility
	Parks		LGA outline



Fishermans Bend Task Force	Job Number	31-34251
Fishermans Bend Utility Infrastructure	Revision	B
	Date	15 Sep 2016

Fishermans Bend Precincts

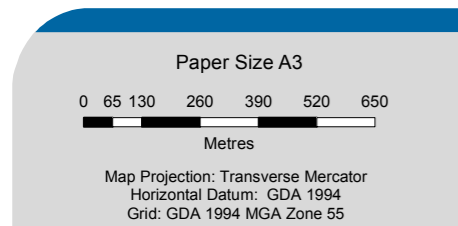

LEGEND

- | | | |
|--------------------------------------|-------------|----------------|
| Melbourne Water Drainage Assets | Highway | Reserve |
| City Of Melbourne Drainage Assets | Arterial | Sport facility |
| City of Port Phillip Drainage Assets | Collector | Parks |
| Precinct Boundaries | Railway | LGA outline |
| Special Building | Freeway | Trains |
| Tramway | Highway | Ferry |
| Proposed | Watercourse | Lake |



Fishermans Bend Task Force	Job Number	31-34251
Fishermans Bend Utility Infrastructure	Revision	B
	Date	15 Sep 2016

Drainage Infrastructure Figure 3

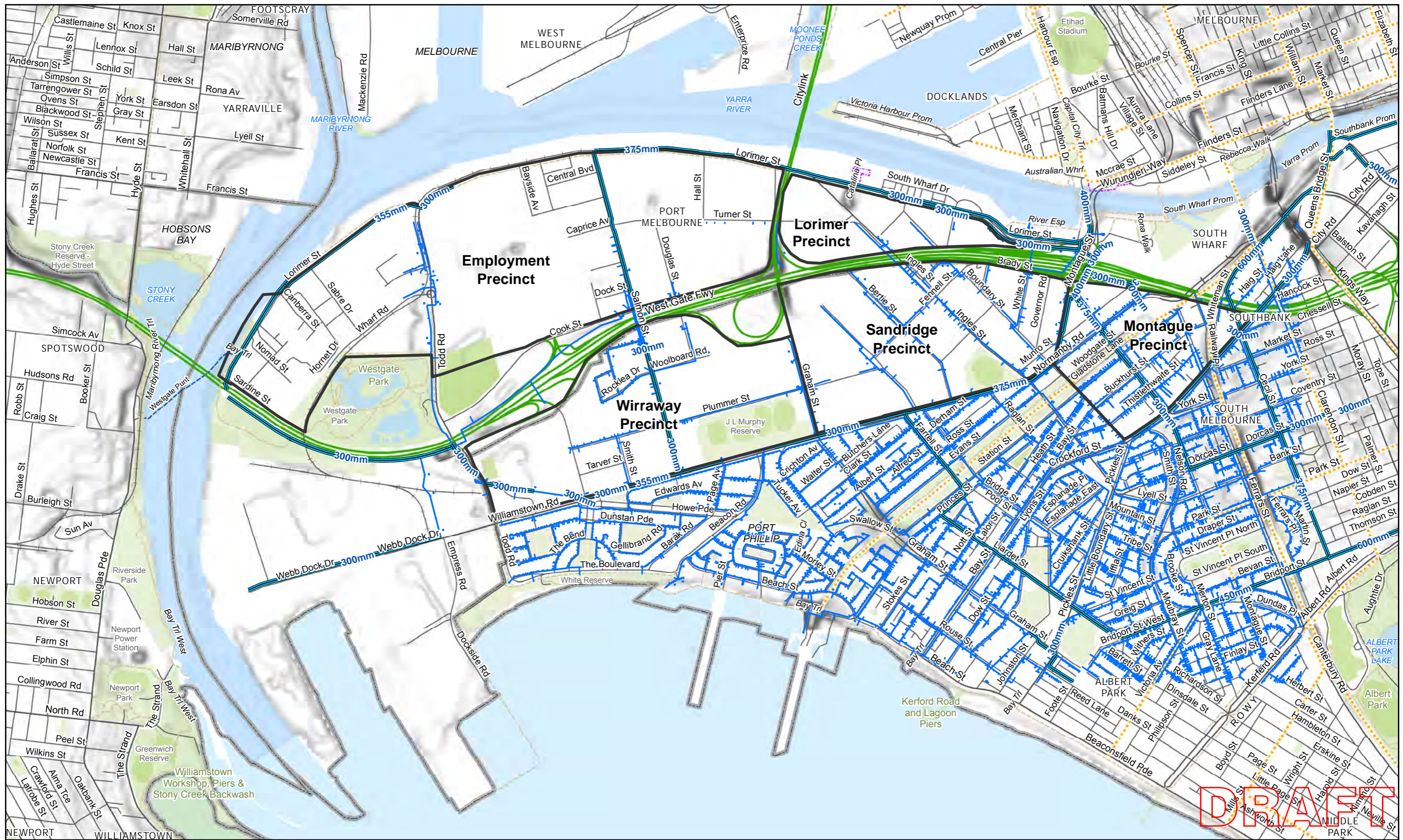

Paper Size A3
 0 65 130 260 390 520 650
 Metres
 Map Projection: Transverse Mercator
 Horizontal Datum: GDA 1994
 Grid: GDA 1994 MGA Zone 55



LEGEND	
	South East Water Distribution Main
	Potable reticulation
	Precinct Boundaries
	Tramway
	Railway
	Freeway
	Highway
	Ferry
	Watercourse
	Lake
	Proposed
	Tracks
	Reserve
	Sport facility
	Parks
	LGA outline



Fishermans Bend Task Force	Job Number	31-34251
Fishermans Bend Utility Infrastructure	Revision	B
	Date	15 Sep 2016

Potable Water Infrastructure Figure 1



<p>Paper Size A3</p> <p>0 65 130 260 390 520 650</p> <p>Metres</p> <p>Map Projection: Transverse Mercator Horizontal Datum: GDA 1994 Grid: GDA 1994 MGA Zone 55</p>		<p>LEGEND</p> <table border="0"> <tr> <td> South East Water Sewer Main</td> <td> Precinct Boundaries</td> <td> Highway</td> <td> Trams</td> <td> LGA outline</td> </tr> <tr> <td> Sewer network</td> <td> Tramway</td> <td> Arterial</td> <td> Ferry</td> <td> Reserve</td> </tr> <tr> <td> Melbourne Water Sewer Main</td> <td> Railway</td> <td> Collector</td> <td> Watercourse</td> <td> Sport facility</td> </tr> <tr> <td> Freeway</td> <td> Lake</td> <td> Proposed</td> <td> Lake</td> <td> Parks</td> </tr> </table>	South East Water Sewer Main	Precinct Boundaries	Highway	Trams	LGA outline	Sewer network	Tramway	Arterial	Ferry	Reserve	Melbourne Water Sewer Main	Railway	Collector	Watercourse	Sport facility	Freeway	Lake	Proposed	Lake	Parks		<p>Fishermans Bend Task Force Job Number 31-34251 Fishermans Bend Utility Infrastructure Revision B Date 15 Sep 2016</p> <p>Sewer Infrastructure Figure 2</p>
South East Water Sewer Main	Precinct Boundaries	Highway	Trams	LGA outline																				
Sewer network	Tramway	Arterial	Ferry	Reserve																				
Melbourne Water Sewer Main	Railway	Collector	Watercourse	Sport facility																				
Freeway	Lake	Proposed	Lake	Parks																				

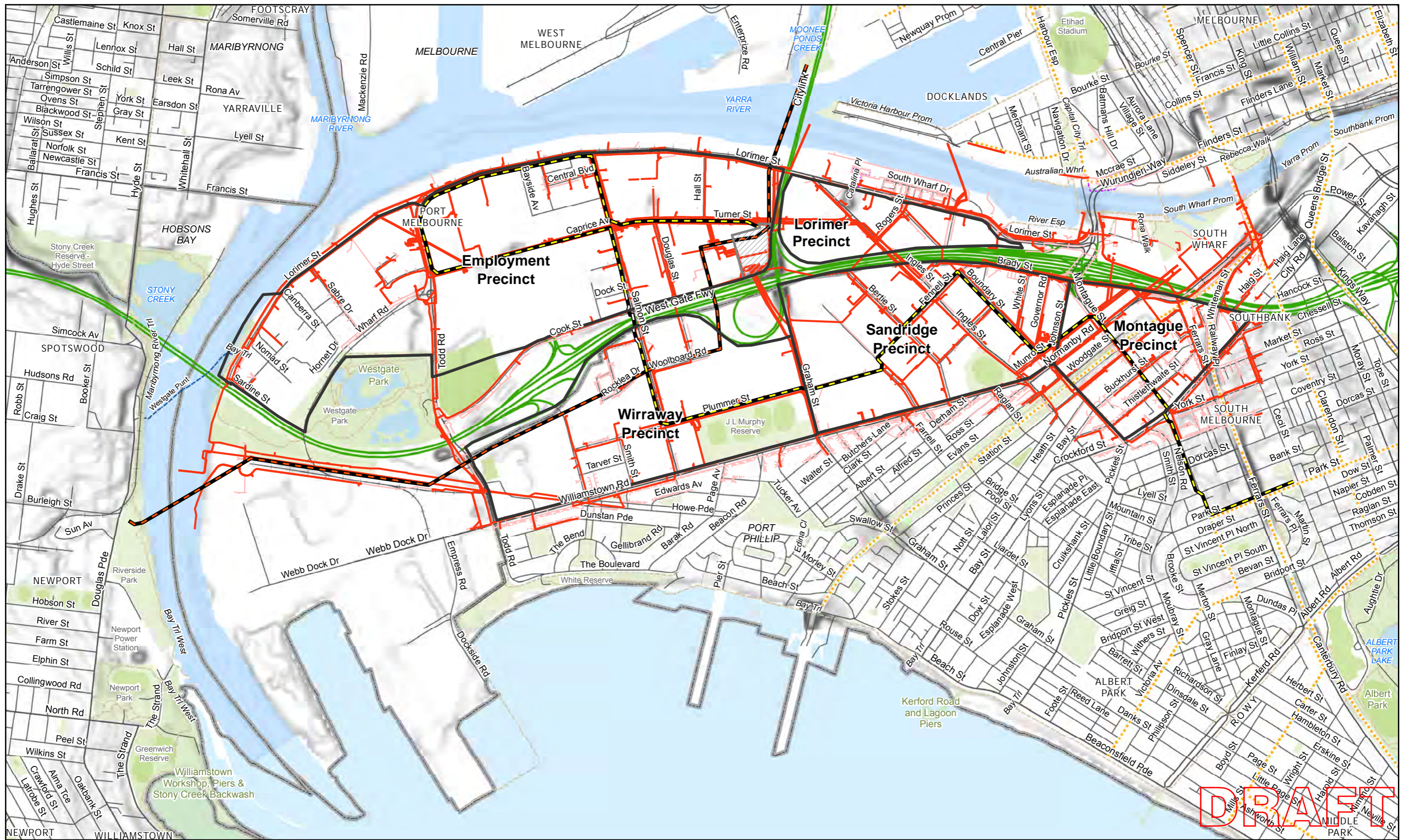

Paper Size A3
 0 65 130 260 390 520 650
 Metres
 Map Projection: Transverse Mercator
 Horizontal Datum: GDA 1994
 Grid: GDA 1994 MGA Zone 55



LEGEND		Ausnet Assets (Updated data yet to be received, from previous Fishermans Bend Projects)		CitiPower		Other Assets	
	Fishermans Bend Terminal Station		220kV Transmission		HV Cable/Line		Freeway
	Precinct Boundaries		Overhead Fibre		LV Cable/Line		Highway
	LGA outline		Underground Fibre		Tramway		Arterial
	Parks		Railway		Collector		Watercourse
	Reserve		Proposed		Lake		Ferry
	Sport facility		Tracks		LGA outline		Watersource



Fishermans Bend Task Force Job Number 31-34251
 Fishermans Bend Utility Infrastructure Revision B
 Date 15 Sep 2016

Electrical Infrastructure Figure 1

© 2016. Whilst every care has been taken to prepare this map, GHD (and DATA CUSTODIAN) make no representations or warranties about its accuracy, reliability, completeness or suitability for any particular purpose and cannot accept liability and responsibility of any kind (whether in contract, tort or otherwise) for any expenses, losses, damages and/or costs (including indirect or consequential damage) which are or may be incurred by any party as a result of the map being inaccurate, incomplete or unsuitable in any way and for any reason.
 Data source: DELWP, VicMap, 2016; GHD, 2016; CitiPower, Electrical Infrastructure (Provided 17/7/2016); Ausnet, Electrical Infrastructure (Updated data yet to be received, from previous Fishermans Bend Projects), 2013 Created by: splaird
 180 Lonsdale Street Melbourne VIC 3000 Australia T 61 3 8687 8000 F 61 3 8687 8111 E melmail@ghd.com W www.ghd.com

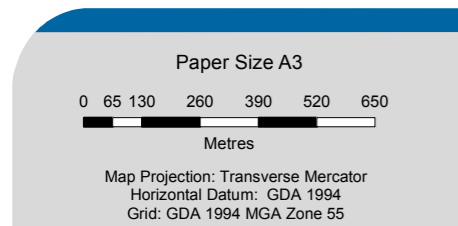

LEGEND	
Nextgen Cable	Optus Underground Fibre
TPG Cable	Telstra Cables
Optus Aerial Fibre	Freeway
Optus Aerial Coax	Highway
Tramway	Railway
Arterial	Collector
Freeway	Proposed
Highway	Tracks
Ferry	Watercourse
Lake	Reserve
Reserve	Sport facility
Parks	Precinct Boundaries
Precinct Boundaries	LGA outline



Fishermans Bend Task Force Job Number 31-34251
 Fishermans Bend Utility Infrastructure Revision B
 Date 15 Sep 2016

Telecommunications Infrastructure Figure 1

Appendix C – Sewer Mining Plant Facility

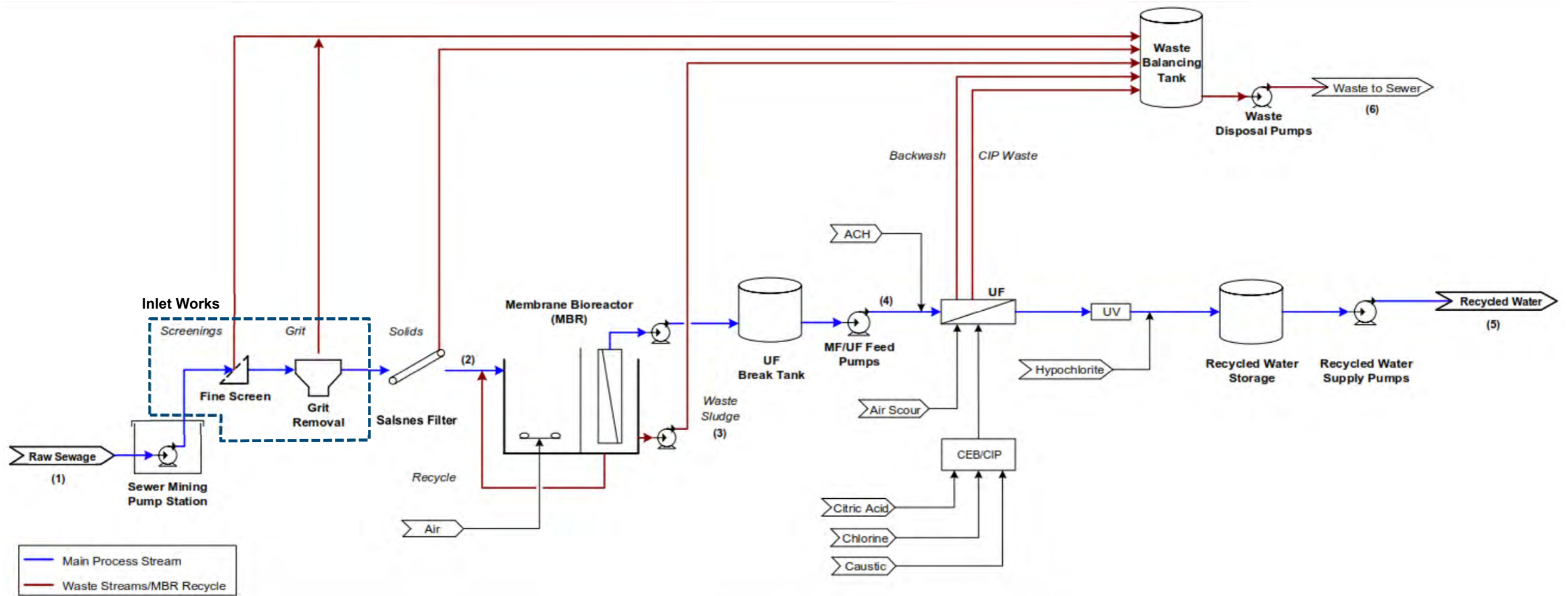

Major Stream Flows and Loads (18.5 ML/d)							
Parameter	Unit	Raw Sewage (1)	MBR Inlet (2)	Waste Sludge (3)	UF Feed (4)	Recycled Water (5)	Waste to Sewer (6)
Stream No.		1	2	3	4	5	6
Flow rate	ML/d	21.2	21.0	0.4	20.6	18.5	2.7
Flow rate	ML/y	7700	7700	150	7500	6800	1000
TSS	tonne DS/d	6.8	3.4	3.3	Negligible	Negligible	6.7

Major Stream Flows and Loads (36 ML/d)							
Parameter	Unit	Raw Sewage (1)	MBR Inlet (2)	Waste Sludge (3)	UF Feed (4)	Recycled Water (5)	Waste to Sewer (6)
Stream No.		1	2	3	4	5	6
Flow rate	ML/d	40.0	39.6	0.8	38.8	34.9	5.1
Flow rate	ML/y	14600	14400	300	14200	12700	1900
TSS	tonne DS/d	12.8	6.4	6.2	Negligible	Negligible	13.3

Fishermans Bend SMP Process Flow Diagram and Hydraulic Balance



Appendix D – Sewage Extraction & Transfer System

DRAFT

Appendix D – Sewage Extraction & Transfer System

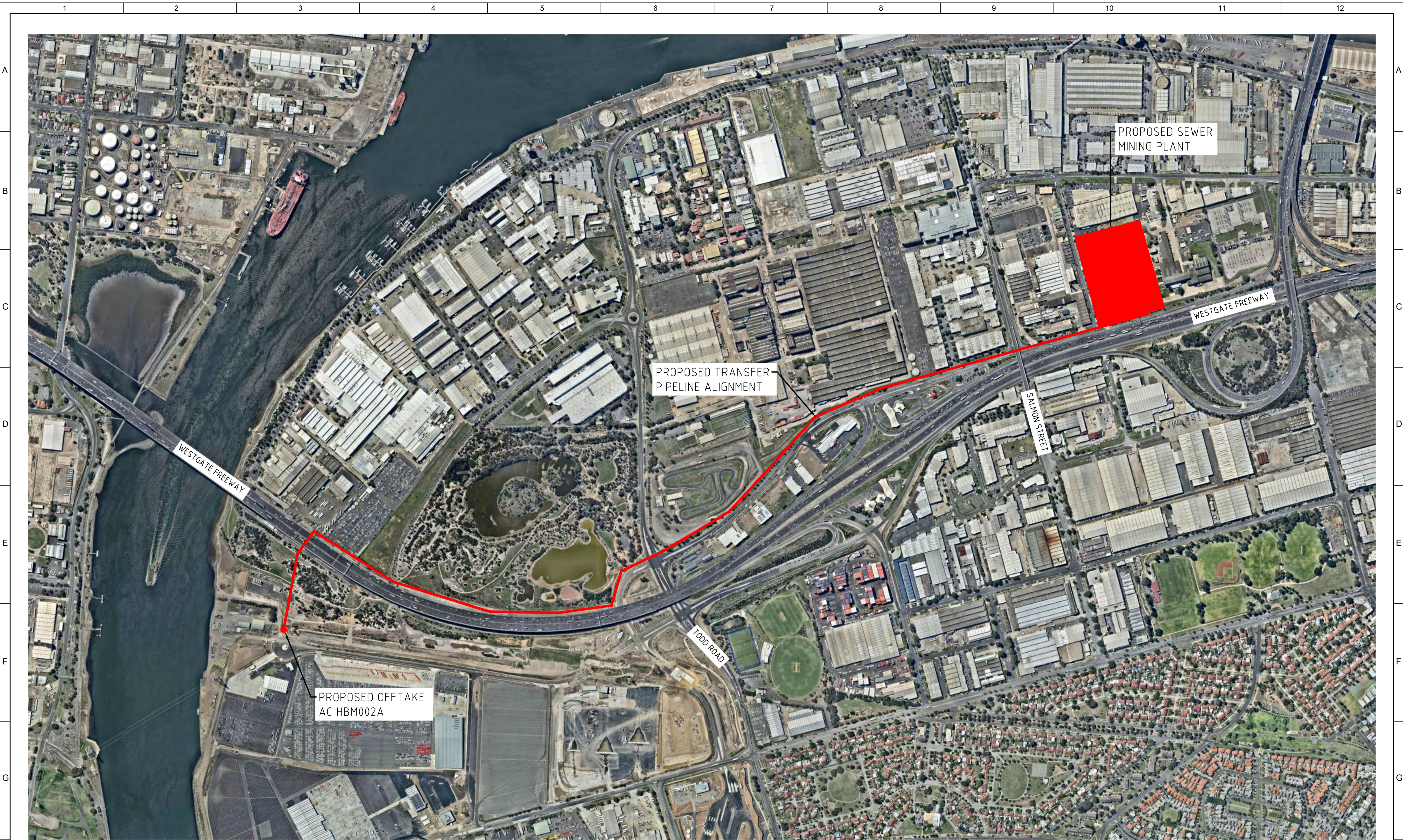

Plot Date: 25 July 2016 - 2:33 PM
 Plotted by: Tony Jensen, #####
 Cad File No: I:\ghd\ghd\AU\Wellbourne\Projects\31-33795\CADD\Drawings\31-33795-FIG01-FIG02.dwg

Note: # indicates signatures on original issue or last revision of drawing

REF.	ZONE	REVISION	DATE	APP'D.	CAD FILE NO.
A		CONCEPT DESIGN			31-33795-FIG01-FIG02.dwg

Copyright - "This document is and shall remain the property of GHD Pty Ltd."
 GHD Conditions of Use.
 "This document may only be used for the purpose for which it was commissioned & in accordance with the terms of engagement for the commission."

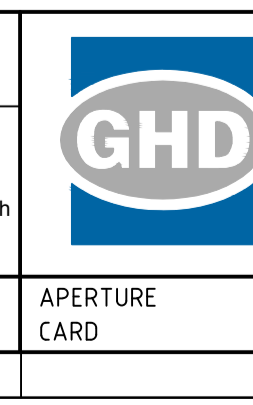

Level 2, 45 Brougham Street Geelong VIC 3220 Australia
 T 61 3 5273 1800 F 61 3 5273 1801
 E gexmail@ghd.com.au W www.ghd.com.au

APERTURE CARD
A1 G.H.D. DWG. NO. **31-33795-FIG01**

DESIGNED	DRAWN	SEWL PROJECT MANAGER
DESIGN CHECK	DRAFT CHECK	SEWL PROJECT DIRECTOR
APPROVED		

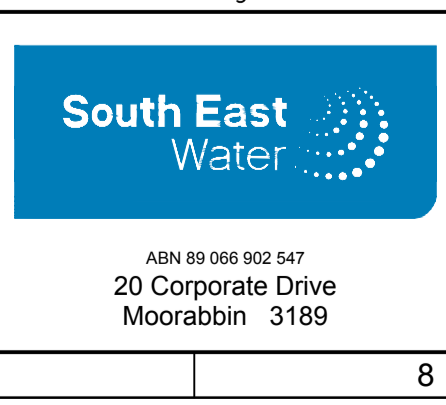

FISHERMANS BEND
FISHERMANS BEND SEWER MINING PLANT CONCEPT DESIGN
TRANSFER PIPELINE
DN450 18.5 MLD
DN600 36.0 MLD

DO NOT SCALE		
SCALE: NTS		
DRAWING NUMBER		A
NUMERAL	REV	

CONCEPT DESIGN

Appendix E – APA and Viva Energy Guidelines to Planning and Development around High Pressure Gas and Fuel Transmission Pipelines

1 July 2016

Fishermans Bend Task Force
Department of Environment, Land, Water & Planning
1 Spring Street
MELBOURNE VIC 3000
GPO Box 500
EAST MELBOURNE VIC 8002

Email to: fishermansbend@delwp.vic.gov.au

BY EMAIL

Dear Sir/Madam,

RE: FISHERMAN'S BEND PRECINCT STRUCTURE PLAN & URBAN RENEWAL PROJECT - APA SUBMISSION.

This letter communication is in response to the Fisherman's Bend Precinct Structure Plan & Urban Renewal Project (*herein the PSP*). APA VTS Australia (Operations) Pty Ltd (*herein APA*) provides these comments on the proposed development around the known APA pipeline assets, adjacent to the study area (see figure 1). APA has the following comments and recommendations in relation to the proposal.

APA has three pipelines within the vicinity of the Study Area:

Table 1: Transmission gas pipelines in the area of consideration

Pipeline	Pipeline Licence	Easement Width (m)	Diameter (mm)	Measurement Length
West Melbourne to Brooklyn	PL108 (T33)	N/A	750	450
Dandenong to West Melbourne	PL36 (T16)	N/A	750	450
Port Melbourne to Symex Holdings	PL164 (T89)	N/A	150	77

Note: measurement length is applied to either side of the pipeline.

APA would like to respond by expressing direct interests in the development of the Fisherman's Bend Precinct Structure Plan area and the future use of lands in the vicinity of its pipeline assets for residential, commercial and public open space purposes. It is APA's objective to protect human life and infrastructure whilst ensuring future land use, subdivision and development will not inhibit the potential of an existing high pressure transmission pipeline system to be able to provide capacity required to meet the needs for natural gas in Victoria.

In APA's previous response dated 22 November 2013, APA had included attachments indicating the legislative requirements of development within the vicinity of high pressure gas pipeline. These documents are still relevant and include:

- APA VTS Australia's Guidelines (Appendix 1)
- AS2885, Part 1, Clause 4.3.4 - Primary Location Classification (Appendix 2)
- AS2885, Part 1, Clause 4.7.4 - Change of Location Class (Appendix 3)

For your benefit, these attachments have once again been incorporated into this documented response.

From the information supplied the proposed PSP will significantly impact on APA assets on the land parcel, which increases the risk of our pipeline being detrimentally impacted upon. APA recognises the need for changes in land use and APA monitors its assets and operations accordingly, to ensure that urban encroachment, development and third party crossings are managed appropriately. For your information, APA has developed general guidelines on development within close proximity to its assets to reduce the risk to life and property (see Appendix 1).

We wish to emphasise it is APA's intent to ensure that high pressure gas pipelines and local communities are safely protected; in accordance with Australian Standards 2885 (AS2885) for Pipelines – Gas and Liquid Petroleum (Part 1). For new residential development within close proximity to the gas transmission pipelines, APA must be notified to enable the development to be considered from a safety perspective. We wish to emphasise that our intent is to ensure that transmission pressure gas pipelines and local communities are safely protected with minimum impact; in accordance with Australian Standards 2885 (AS2885) for Pipelines – Gas and Liquid Petroleum (Part 1), explicitly addressed in Clause 4.7.4 & 4.7.3 (Appendix 2 & 3) and subject to required Safety Management Study (SMS). Our technical regulator, Energy Safe Victoria (ESV) and the AS2885 impose obligations on pipeline licensees to maintain appropriate safety risk levels of pipelines despite changes in the surrounding environment and population.

It is recommended that high density residential development or other sensitive land uses should be located beyond the "measurement length" when planning or developing land in the vicinity of any high pressure gas transmission infrastructure as is proposed within the subdivision. Land in close proximity to the high pressure transmission pipeline should be developed to provide a level of separation whereby sensitive, high density and susceptible land uses are avoided where injury could result from a pipeline incident. This separation or "**measurement length**" (Table 1) clearly defines the region that would be affected by the worst case scenario pipeline failure and identifies the distance where development should be carefully designed and considered by the planning authority in relation to gas transmission pipelines.

APA has completed the review of the PSP and associated documents in relation to its high pressure gas transmission pipelines and associated infrastructure and submits the following comments to Government:

First and foremost APA notes that an independent Ministerial Advisory Committee (*herein* MAC) was announced on 21 July 2015 to advise the Minister for Planning on development within the Fisherman's Bend project area. The MAC provided a report to the Minister for Planning on the effectiveness of the planning process to date for the broader PSP study area. It is understood that the MAC continues to provide independent advice on the planning and future of the Fisherman's Bend Precinct.

APA is disappointed in the responses to numerous planning applications within the precinct area thus far. Numerous applications have bypassed normal planning practices and have been approved by the Minister of Planning without any consultation with stakeholders integral to the health and safety of the future local community. Due to the lack in consultation with APA, numerous planning decisions have been made resulting in important pipeline safety policies and regulations not taken into account. This failure to take such actions into account creates an unacceptable risk of external interference to APA's critical assets.

APA's pipeline assets located within the Victorian Transmission System have been classified as 'Vital Critical Infrastructure' under the *Emergency Management Act, 2013*. It is for this reason that planning and development around pipeline assets displayed in Table 1 above takes into account the sensitive and critical nature of the gas transmission pipeline assets.

From the information supplied, the proposal will significantly impact on APA's assets within the study area.

Table 2: Fisherman's Bend Precincts and associated implicated High Pressure Gas Transmission.

Precinct Name	Pipelines Affected
Montague Precinct	PL108 (T33)
	PL36 (T16)
	PL164 (T89)
Sandridge Precinct	PL108 (T33)
	PL164 (T89)
Lorimer Precinct	NIL
Wirraway Precinct	PL108 (T33)
Employment Precinct	PL108 (T33)

- APA understands that the Metropolitan Planning Authority (*herein MPA*) is in the process of preparing a Development Contributions Plan Overlay under clause 45.06 of the local planning scheme which once finalised will apply to all land within the PSP study area. Due to the significant implications of developing lands within the measurement length of such significant high pressure gas transmission pipeline assets it is recommended that appropriate pipeline safety measures be incorporated into this piece of legislation in the future.
- Detailed cross-sections showing the location of the high pressure gas transmission pipelines should be produced as displayed in Figure 2 in consultation with APA to ensure all development along the APA pipeline right-of-way is standardised and protects the integrity of the pipeline asset. These cross-sections should be attached as an appendix to the Fisherman's Bend Strategic Framework Plan and/or final Precinct Structure Plan documents. It is imperative that potential developers are well aware of the pipeline assets within the measurement length and the implications associated with such assets. Currently, cross-sections such as for Buckhurst Street (Figure 2) do not show the APA pipeline asset.
- The proposed land use changes adjacent to the pipeline assets will trigger the requirement of a Safety Management Study in line with the Australian Standard AS-2885.
- The proposed land use surrounding the APA pipeline assets (see Figure 3), within the measurement length of APA pipelines will likely be classified as a sensitive use under the Australian Standard AS-2885.
- Numerous community infrastructure developments including landscaping in close proximity to the APA pipelines are proposed as demonstrated in Figure 3 attached within the Ferrars St and Buckhurst Street sections of the Montague precinct area. It is essential that APA is consulted in such planning from an early onset to ensure the pipeline asset is not placed at an increased risk or threat. APA notes it must have unimpeded 24 hour access to the pipeline for monitoring and maintenance purposes. Any proposed development or land use must not impact on APA's ability to meet their requirements as the pipeline licensee to maintain its' asset in line with the *Standard* and the *Act*.
- Restrictions on the use of the pipeline Right-of-Way (*herein the ROW*) on all proposed lands within three metres of the edge of pipeline within the Precinct Structure Plan Area (or in close vicinity of the pipeline) will be enforced in accordance with the *Victorian Pipelines Act, 2005*. In particular:
 - No structure will be permitted within three (3) metres of a pipeline asset without prior written approval.
 - Line of sight along the pipeline ROW must be maintained.
 - Three (3) metre minimum clearance between the pipeline and any vegetation greater than 0.5m in height must be maintained at all times.
- Detailed engineering plans for any proposed future public open space developments running parallel with APA high pressure gas transmission pipelines will be required by APA for assessment

and prior to future works to ensure its pipeline assets are not placed at an unacceptable risk. APA notes that for all developments adjacent to the pipeline or in the near vicinity, construction methodology and proposed plant and equipment to be utilised during construction for any proposed works will be required prior to construction for assessment and approval by APA prior to future construction works. This would be best implemented through the mandatory requirement of a Construction Management Plan (CMP). This CMP requirement and approval of the CMP by APA has been utilised in numerous other PSP developments throughout Melbourne and should be applied accordingly.

- Any proposed structures such as light poles and/or landscaping within the APA ROW must be approved by APA. APA must assess whether this will be classified as a permanent structure under section 120 of the Victorian Pipelines Act 2005.
- APA reserves the right to review any engineering plans developed that will impact on its existing pipeline infrastructure in the future.

It is recommended that project managers and/or design engineers have ongoing correspondence with APA in the future to discuss the scope of issues relating to any planning, design or construction activities adjacent to and/or across APA infrastructure to ensure its assets are thoroughly protected. It is APA's intent is to ensure that transmission pressure gas pipelines are safely protected with minimum impact on and mitigating any potential risks and proposed encroachment to ensure the integrity of its pipeline assets.

For any further enquiries relating to this submission please feel free to contact the Infrastructure, Planning & Protection Team on (03) 9797 5118 or (03) 9797 5265 or by email ipp@apa.com.au.

Yours faithfully,



LACHLAN MARSHALL
LAND AGENT- VICTORIA

CC: Daniel Tucci, Metropolitan Planning Authority, Port Phillip Council, Melbourne City Council, Energy Safe Victoria

- Figure 1: APA VTS Australia Pipeline Assets within Study Area.
- Figure 2: Proposed Buckhurst Street Public Green Link Cross Section.
- Figure 3: South Melbourne Ferrars St Primary School & Integrated Community Facilities Site Context and approximate location of pipeline asset.
- Figure 4: Proposed Ferrars/Buckhurst Streets Illustrative Plan & Site Context and approximate location of pipeline asset.
- Appendix 1: APA VTS Australia's Guidelines to Planning and Development around High Pressure Gas Transmission Pipelines.
- Appendix 2: Clause 4.7.4 Australian Standards 2885 for Pipelines – Gas and Liquid Petroleum (Part 1) - Primary Location Classification
- Appendix 3: Clause 4.3.4 Australian Standards 2885 for Pipelines – Gas and Liquid Petroleum (Part 1) - Change of Location Class

Figure 1: APA VTS Australia Pipeline Assets within Study Area

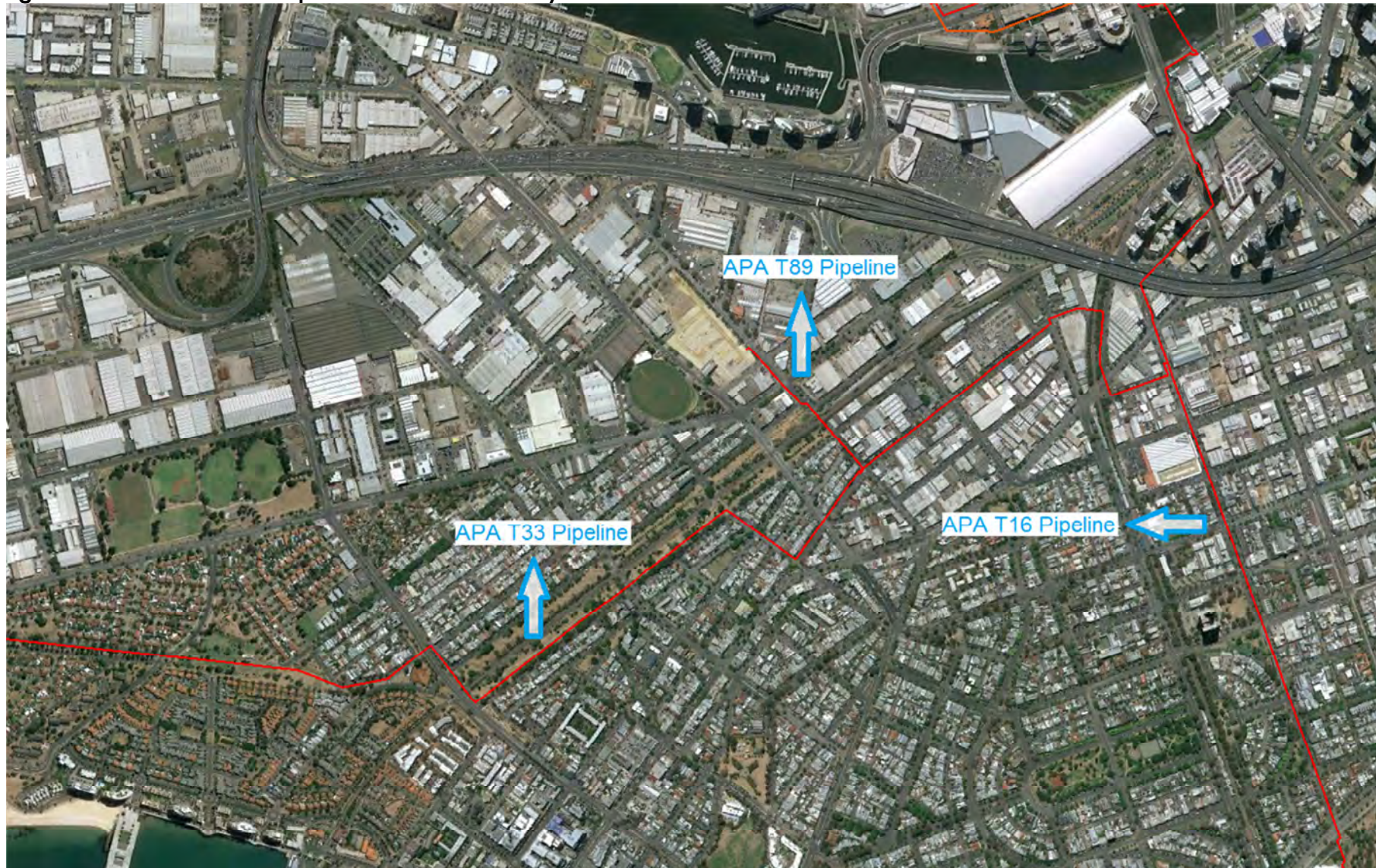

APA Group comprises two registered investment schemes, Australian Pipeline Trust (ARSN 091 678 778) and APT Investment Trust (ARSN 115 585 441), the securities in which are stapled together. Australian Pipeline Limited (ACN 091 344 704) is the responsible entity of those trusts. The registered office is HSBC building, Level 19, 580 George Street, Sydney NSW 2000.

Figure 2: Proposed Buckhurst Street Public Green Link Cross Section.

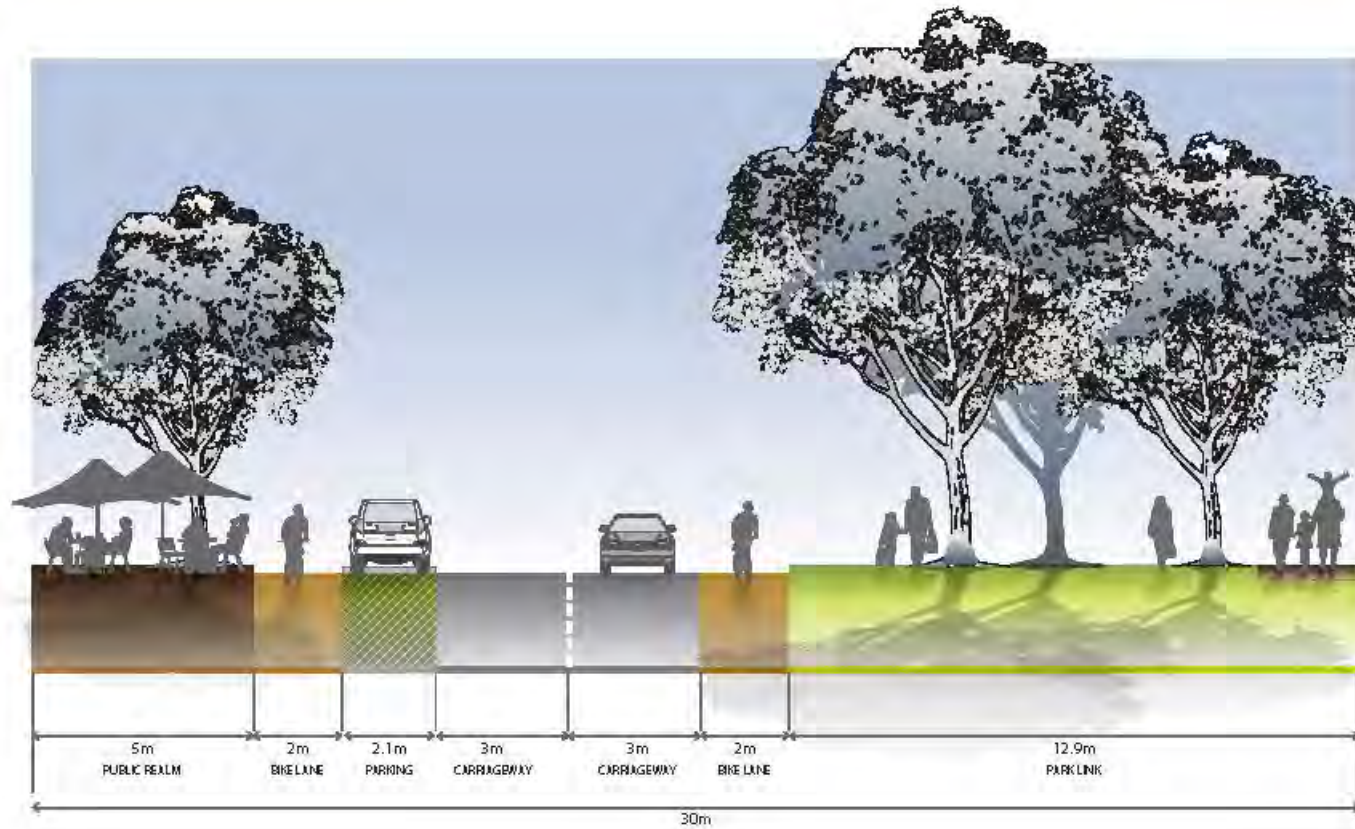

Buckhurst Street Green Link

Figure 3: South Melbourne Ferrars St Primary School & Integrated Community Facilities Site Context and approximate location of pipeline asset.



APA Group comprises two registered investment schemes, Australian Pipeline Trust (ARSN 091 678 778) and APT Investment Trust (ARSN 115 585 441), the securities in which are stapled together. Australian Pipeline Limited (ACN 091 344 704) is the responsible entity of those trusts. The registered office is HSBC building, Level 19, 580 George Street, Sydney NSW 2000.

Figure 4: Proposed Ferrars/Buckhurst Streets Illustrative Plan & Site Context and approximate location of pipeline asset.



PROPOSED ILLUSTRATIVE PLAN

INDICATE SURROUNDING DEVELOPMENT SHOWN

APA Group comprises two registered investment schemes, Australian Pipeline Trust (ANCI 091 070 770) and AP1 Investment Trust (ANCI 115 505 991), the securities in which are stapled together. Australian Pipeline Limited (ACN 091 344 704) is the responsible entity of those trusts. The registered office is HSBC building, Level 19, 580 George Street, Sydney NSW 2000.

Appendix 1: APA VTS Australia's Guidelines to Planning and Development around High Pressure Gas Transmission Pipelines.

1. Planning Controls

Operations of gas transmission pipelines carry a level of risk, which must be assessed when considering development proposals in the vicinity of high pressure transmission pipelines, to ensure that risk to people, property and the environment is within acceptable levels.

Whilst Australian gas pipelines industry has an excellent safety record, in case of a pipeline failure an area of several hundred metres can be significantly impacted. The most frequent cause of pipeline failure worldwide is damage caused by external interference resulting from multiple activities such as construction or maintenance activities on or near gas pipelines.

Whilst the land that is required to control access to the pipeline itself is set aside in an **easement** in most situations, a much larger buffer should be considered when planning or developing land in the vicinity of any high pressure gas infrastructure.

The "**measurement length**" clearly defines the region that could be affected by the worst case scenario pipeline failure and identifies the distance where development proposals should be referred to the pipeline owners by the planning authority.

If there is any change in land use/zoning, in pipeline location classification or a construction activity is proposed within the measurement length, AS2885 requires a detailed **Safety Management Study** to be undertaken, which incorporates performing a risk assessment. For example, as a location classification changes from rural to residential (Appendix 2 and 3), the level of pipeline protection required normally increases to ensure protection of the pipeline and to manage the risk to the community and the environment.

2. All proposed development needs to be restricted in the pipeline's easements and/or within close proximity to the pipeline

APA owns and operates multiple natural gas transmission pipelines of various wall thickness and pressures throughout Victoria.

APA would oppose road construction (including water courses or structures) within or on the transmission pipeline easements parallel to or over the pipeline as it seeks to minimise construction works in the easements to reduce the likelihood of excavations potentially causing damage to the pipelines.

We advise that APA's position is supported by Government legislation and Australian Safety Standards:

- Pipelines Act (2005) - there is restrictions on works within close proximity to APA's pipelines.
- APA has restrictive covenants that control development within its easements, for example, restrictions on structures and excavation.
- AS2885.1 - APA has a duty to review and comment on changes in land uses in close proximity to the pipeline.

Each easement could be incorporated into a proposed development subject to early consultation with APA as periodic access is required to our pipelines.

Most transmission pipelines are protected by a registered easement which varies in width from 6.5 to 35m; however there is high pressure transmission pipelines located in various road reserves or

Government land without a registered easement. In such cases, a "Permit to Work", issued by APA, is required for any proving and/or construction activity deeper than 300mm within 3m of a transmission pipeline.

3. Crossing of an APA VTS Australia high pressure transmission pipeline or easement

Crossing high pressure transmission pipelines and/or any related easements by roads, rails and other services, would be permitted in principle with prior approval of APA (at a 90 degree angle) as the pipelines might need to be re-engineered for the proposed crossing.

Further assessments of road crossings, other services and potential impact on the pipeline will need to be assessed and conditions issued on a case by case basis upon consideration of a number of factors such as: the depth of pipeline cover, pipeline recoating, relocation of the pipeline and future pipeline accessibility, to the applicant's cost.

Each pipeline easement could be incorporated into a reserve or open space, that is, in other Structure Plans the easements have served as cycle links or linear paths connecting areas of open space.

The easement must be left grassed with no large trees or bushes planted that may cause damage to the pipeline coating. Any flora deemed a danger to the integrity of the pipeline will be removed. Plant species placed within the easement must be approved by APA.

Due to periodic access required to our pipelines for maintenance, significant disturbance to the easement may occur due to excavation around the pipeline.

4. Developments within the "measurement length" – urban encroachment issues

High pressure gas transmission pipelines have the potential to cause major damage if the gas ignites in case of a rupture. APA constantly monitors and maintains these pipelines to ensure their integrity; therefore the likelihood of a major incident is highly unlikely, however, under the safety obligations of AS2885, APA is required to ensure that adequate measures are taken to minimise the risk to public safety in close proximity of its pipelines.

The 'measurement length' relevant to APA pipelines in the area vary and proximity is determined by the diameter of the pipeline and its operating pressures.

For proposals within the 'measurement length' a pipeline risk management plan will be required to demonstrate that the risk from the pipeline is within acceptable levels. The risk management plan may require a safety assessment and must be undertaken in consultation with the pipeline owner/operator.

The safety assessment is conducted in the form of a Safety Management Study (SMS). The SMS is defined as the process that identifies threats to the pipeline system and applies controls to them, and (if necessary) undertakes assessment and treatment of any risks to ensure that residual risk is reduced to an acceptable level.

AS 2885.1 explicitly addresses the urban encroachment problem in **Clause 4.7.4** (Appendix 2); Change of Location Class. It addresses situations where higher population densities occur in areas where they were previously not permitted. In that situation the standard requires that:

"...a safety assessment shall be undertaken and additional control measures implemented until it is demonstrated that the risk from a loss of containment involving rupture is As Low As Reasonably Possible (ALARP)." **AND**

"...the assessment shall demonstrate that the cost of the risk reduction measures provided by alternative solutions is grossly disproportionate to the benefit gained from the reduced risk that could result from implementing any of the alternatives"

The assessment must include consideration of alternative risk reduction measures including Maximum Allowable Operating Pressure (MAOP) reduction, pipe replacement, pipeline relocation, modification of land use and additional physical and procedural protection. All measures to be further discussed and considered on specific developments upon early consultation with APA.

The additional physical and procedural external interference protection measures are:

- Physical controls: separation (burial, exclusion & barrier) and resistance to penetration (wall thickness and barrier to penetration).
- Procedural controls: pipeline awareness (landowner, third party liaison, community awareness program, one call service, marking, activity agreements with other entities) and external interference detection (planning notification zones, patrolling & remote intrusion monitoring).

AS2885 requires a metre by metre qualitative analysis to identify each threat to pipeline integrity followed by a defined process to manage each threat either by eliminating it through external interference or design processes, or by development of management procedures to reduce the risk from hazardous events to negligible, low or in unresolved cases, to ALARP.

APA will also conduct preliminary calculations and assessments of existing pipeline's credible threats to either rupture or create a hole. In addition APA would seek assistance from local Council in preventing the use of rippers and horizontal directional drills (HDDs) working in the vicinity of the pipeline.

Based on the above, APA recommends that "T2" high density and "Sensitive" land uses are preferably located the corresponding measurement length (see Table 1) from the pipeline away from either edge of the pipeline's easements.

"T2" high density and "Sensitive" land uses are defined in AS2885 as:

"T2" High density - Applies where multi-storey development predominates or where large numbers of people congregate in the normal use of the area. High density includes areas of public infrastructure serving the high density use; roads, railways, major sporting and cultural facilities and land use areas of major commercial developments; cities, town centres, shopping malls, hotels and motels." (Section 4.3.4[d] of AS2885).

"Sensitive" – The sensitive use location class identifies land where the consequences of a failure may be increased because it is developed for use by sectors of the community who may be unable to protect themselves from the consequences of a pipeline failure. Sensitive uses are defined in some jurisdictions but include schools, hospitals, aged care facilities and prisons. Sensitive use location class shall be assigned to any portion of pipeline where there is a sensitive development within a measurement length. It shall also include locations of high environmental sensitivity to pipeline failure. The design requirement for high density shall apply." (Section 4.3.5[a] of AS2885).

We understand that the predominant land use within the measurement length of the gas pipeline in the Planning Scheme amendments as currently presented is residential land. Residential is defined in AS2885 as:

*“**Residential** applies where multiple dwellings exist in proximity to each other and dwellings are served by common public utilities. Residential includes areas of land with public infrastructure serving the residential use; roads, railways, recreational areas, camping grounds/caravan parks, suburban parks, small strip shopping centres. Residential land use may include isolated higher density areas provided they are not more than 10% of the land use. Land used for other purposes but with similar population density shall be assigned Residential location class.”* (Section 4.3.4[c] of Australian Standard AS2885).

However, there could be possible conflicts if the location or isolated high density area land uses within the measurement length were to change and therefore APA would in that case request that “T2” high density and “Sensitive” is relocated preferably to a position located at least the measurement length from the pipelines away from either edge of the pipeline’s easements.

Appendix 2: Clause 4.7.4 Australian Standards 2885 for Pipelines – Gas and Liquid Petroleum (Part 1) - Primary Location Classification

4.7.4 Change of location class

Where there are changes in land use planning (or land use) along the route of existing pipelines to permit Residential, High Density, Industrial, or Sensitive development or Heavy Industrial development in areas where these uses were previously prohibited, a safety assessment shall be undertaken and additional control measures implemented until it is demonstrated that the risk from a loss of containment involving rupture is ALARP.

A location class change to Heavy Industrial requires compliance with this Clause only when pipeline failure in this location would create potential for consequence escalation.

This assessment shall include analysis of at least the alternatives of the following:

- (a) MAOP reduction (to a level where rupture is non-credible).
- (b) Pipe replacement (with no rupture pipe).
- (c) Pipeline relocation (to a location where the consequence is eliminated).
- (d) Modification of land use (to separate the people from the pipeline).
- (e) Implementing physical and procedural protection measures that are effective in controlling threats capable of causing rupture of the pipeline.

For the selected solution, the assessment shall demonstrate that the cost of the risk reduction measures provided by alternative solutions is grossly disproportionate to the benefit gained from the reduced risk that could result from implementing any of the alternatives.

Appendix 3: Clause 4.3.4 Australian Standards 2885 for Pipelines – Gas and Liquid Petroleum (Part 1) - Change of Location Class

Land through which the pipeline passes shall be classified as follows:

- (a) **Rural (R1)** Land that is unused, undeveloped or is used for rural activities such as grazing, agriculture and horticulture. Rural applies where the population is distributed in isolated dwellings. Rural includes areas of land with public infrastructure serving the rural use; roads, railways, canals, utility easements.
- (b) **Rural Residential (R2)** Land that is occupied by single residence blocks typically in the range 1 ha to 5 ha or is defined in a local land planning instrument as rural residential or its equivalent. Land used for other purposes but with similar population density shall be assigned rural residential location class. Rural residential includes areas of land with public infrastructure serving the rural residential use; roads, railways, canals, utility easements.

NOTE: In rural residential societal risk (the risk of multiple fatalities associated with a loss of containment) is not a dominant design consideration.

- (c) **Residential (T1)** Land that is developed for community living. Residential applies where multiple dwellings exist in proximity to each other and dwellings are served by common public utilities. Residential includes areas of land with public infrastructure serving the residential use; roads, railways, recreational areas, camping grounds/caravan parks, suburban parks, small strip shopping centres. Residential land use may include isolated higher density areas provided they are not more than 10% of the land use. Land used for other purposes but with similar population density shall be assigned Residential location class.
- (d) **High Density (T2)** Land that is developed for high density community use. High Density applies where multi storey development predominates or where large numbers of people congregate in the normal use of the area. High density includes areas of public infrastructure serving the high density use; roads, railways, major sporting and cultural facilities and land use areas of major commercial developments; cities, town centres, shopping malls, hotels and motels.

NOTE: In residential and high density areas the societal risk associated with loss of containment is a dominant consideration.

In rural and rural residential areas, consideration shall be given to whether a higher location class may be necessary at any location where a large number of people may be present for a limited period.

NOTE: Examples include roads subject to heavy traffic congestion and sports fields.



19th April 2016

Conditions for Works near Viva Energy Australia Pty Ltd owned and operated High Pressure Pipelines in Victoria

Introduction

Viva Energy Australia Pty Ltd (Viva Energy) on behalf of itself and as operator of W.A.G. Pipeline Proprietary Limited, Newport Industry Pipeline and Crib Point Pipeline operate a number of high pressure licensed pipelines in Victoria. These pipelines contain either crude oil, or refined petroleum products like diesel, LPG, petrol, or aviation fuel.

As the operating pressure can be as high as 9600 kPa damage to the pipelines may result in a potentially hazardous situation in terms of fire and/or explosion, and may lead to substantial environmental impact. Damage could also result in disruption of crude oil supply to refineries, or fuel supply to airports, service stations and other customers. The costs of such damage could result in the liability for payment of costs by the Authority, Principal or Developer responsible.

The requirements below have been put in place by Viva Energy to minimise the risk of damage to the pipelines.

In addition to complying with the requirements set out in these conditions and in the document 'Land Use Planning, Development & Subdivision near Viva Energy Australia owned and operated High Pressure Pipelines in Victoria', Viva Energy may require that anyone who proposes to carry out works in the vicinity of the pipelines:

- (a) grants an easement to Viva Energy which contains provisions to ensure that the pipeline will be adequately protected both during and after the works and that Viva Energy will continue to have rights to access the pipeline; and/or
- (b) enter into an agreement with Viva Energy in relation to the proposed work, which may include indemnities by the authority or developer in respect of any damage to the pipelines arising from the works and provision for recovery of Viva Energy costs in relation to any works which it is required to carry out to protect the pipeline.

Pipeline warning/danger signs

'High Pressure Pipeline' warning/danger signs are placed strategically along the pipeline routes within the vicinity of the pipeline. These signs do not give the exact location of the pipeline. The phone numbers on the signs vary according to the pipeline:

Viva Energy Australia - Pipelines – Emergency 1800 809 691

W.A.G. Pipeline - Emergency 1800 650 523

Lara LPG Pipeline – Emergency 03 5273 8250

Enquiries - (03) 9391 6568

Viva Energy Australia Right of Way Works Permit

Any works within three (3) metres of a licensed pipeline requires a Viva Energy Right of Way (ROW) permit. The ROW permits are obtained from the Pipeline Inspectors.

Notification of Intent

For proposed works within the vicinity of a pipeline, detailed submissions at the concept stage are to be made to Viva Energy Pipelines Manager,

C/o Linda Busbridge - Pipeline Officer by letter or email: linda.busbridge@vivaenergy.com.au

Note: Under section 118 of the Pipelines Act 2005, a person may be guilty of an offence if the person carries out any excavation or bores or opens any ground within 3 metres of a pipeline without either obtaining the authority of the licensee or giving notice to the licensee in accordance with the regulations.

Installation and construction

Submissions including preliminary drawings and scope of work at concept stage (Including but not limited to Service Crossings) are to be made to Viva Energy Pipelines Manager,

C/o Linda Busbridge - Pipeline Officer by letter or email: linda.busbridge@vivaenergy.com.au

Approval from the Pipeline regulator may also be required.

Note: Under section 120 of the Pipelines Act 2005, a person must not construct a building so that any part of it is situated less than 3 meters from a point on the surface of the land, whose position is vertically above a part of the pipeline below the surface unless the Minister has first consented to the construction. Penalties and demolition orders apply to contravene.

Location proving

To ensure that the pipeline is not damaged, HAND EXCAVATED proving must be carried out - in the presence of a Pipeline Inspector - to determine the exact location of the pipeline prior to commencement of detail design and/or construction.

72 hours minimum prior notice of intention to prove dig and/or commence construction shall be given to arrange for a Pipeline Inspector to be on site during the location proving. Contact with an inspector can be made on the following numbers.

No charge is made for this service (unless substantial on-site time for the Pipeline Inspector is required).

Viva Energy Pipelines Coordinator – VIC

Name:	Matt Lynch
Phone:	M 0418 386 764 PH (03) 9391 6568
Email:	matthew.j.lynch@vivaenergy.com.au

Viva Energy Pipelines Maintenance Supervisor

Name:	David Kelly
Phone:	M 0418 386 762
Email:	d.kelly@vivaenergy.com.au

NO MECHANICAL EQUIPMENT is to be used within a horizontal distance of 1.0 m of the proven pipeline location unless approved by the Pipeline Inspector.

Accidental damage

Should any accidental damage be made to the pipeline and/or coating—even of a minor nature—Viva Energy must be notified on the above numbers to enable inspection and subsequent repair.

Note: Under section 119 of the Pipelines Act 2005, a person must not knowingly, recklessly or negligently break, injure, open or tamper with any pipeline. Penalties apply.

Minimum pipeline clearance requirements

The MINIMUM clearances from the pipeline (per the pipeline licensing authority) are as follows:

- (a) 0.5 m to buried equipment or structures less than 1.5 m wide and crossing the pipeline;
- (b) 0.5 m to buried equipment or structures greater than 1.5 m wide and crossing the pipeline;
- (c) 1.0 m to buried equipment or structures laid parallel to the pipeline; and
- (d) 3.0 m to any building* and the extremity of the pipeline (measured horizontally).

Note: * Under section 120 of the Pipelines Act 2005, a person must not construct a building so that any part of it is situated less than 3 metres from a point on the surface of the land whose position is vertically above a part of a pipeline below the surface unless the Minister has first consented to that construction. Penalties and demolition orders apply to contravention.

Excavation within 400 mm of the pipeline is to be backfilled with well compacted good quality packing sand.

Boring works

Where construction is to bore under or over the pipeline, hand excavation 1.0 m adjacent to the pipeline must first be made on the side from which the bore will approach. The above stated minimum clearance is to be confirmed with the Pipeline Inspector once the bore breaks through to this excavation.

Use of explosives

Conditions applying when blasting in the vicinity of the pipeline are as follows:

- (a) No explosives are to be used within 30.0 m of the proven location.
- (b) Persons using explosives must be licensed under the applicable dangerous goods regulations.
- (c) Heavy coir or other approved matting must be used to cover the explosives area.
- (d) 'Cordtex' or other detonating type fuses shall not cross the pipeline if less than 0.5 m cover exists.
- (e) Carriers containing explosives must not be left within 5.0 m of the pipeline during blasting.
- (f) No blasting is to proceed within the limits of clauses (b) and (c) above until approval is given by Pipeline personnel.
- (g) Blasting methods must be arranged to limit ground vibrations to less than 20 mm/s peak particle velocity at any point on the pipeline.

Creagh de Brabander
Pipelines Operations Manager
Viva Energy Australia Pty Ltd

WAG Pipeline Proprietary Limited (ABN 73 004 784 310) is a subsidiary of Viva Energy Australia Pty Ltd.



19th April 2016

Land Use Planning, Development and Subdivision near Viva Energy Australia owned and operated High Pressure Pipelines in Victoria

Introduction

Viva Energy Australia Pty Ltd (Viva Energy) on behalf of itself and as operator of W.A.G. Pipeline Proprietary Limited, Newport Industry Pipeline and Crib Point Pipeline operate a number of high pressure licensed pipelines in Victoria. These pipelines contain either crude oil, or refined petroleum products like diesel, LPG, petrol or aviation fuel.

Although being buried and constructed from high strength steel, damage to the pipeline may occur through unauthorised third party excavation. The purpose of this communication is to raise or to reinforce the awareness of the presence of the pipelines and to identify constraints with respect to the use of the land on and near the pipeline.

In addition to complying with the requirements set out in these conditions and in the document 'Conditions for Works near Viva Energy Australia owned and operated High Pressure Pipelines in Victoria', Viva Energy may require that anyone who proposes to carry out works in the vicinity of the pipeline:

- a) grants an easement to Viva Energy which contains provisions to ensure that the pipeline will be adequately protected both during and after the development and that Viva Energy will continue to have rights to access the pipeline; and/or
- b) enter into an agreement with Viva Energy in relation to the proposed development, which may include indemnities by the authority or developer in respect of any damage to the pipelines arising from the development and provision for recovery of Viva Energy costs in relation to any works which it is required to carry out to protect the pipeline.

Pipeline route and easements

The routes of pipelines are shown on a series of maps. The majority of the pipelines within the metropolitan area are within road reserves. The pipeline route outside of the metropolitan area when originally laid was predominantly through rural and semi-rural private property. Where practical the route was within existing pipeline corridors. Easements were created through this land. Over the years, the lands around the pipelines have gradually been developed with new roads, residential and industrial subdivisions, etc. reducing the extent of rural and semi-rural areas and increasing the urban and industrial areas.

The easement width varies along the route of the pipelines. It should be noted the pipeline is not necessarily located centrally and can be anywhere within the easement.

Constraints

To ensure land use planning, development and subdivision does not jeopardise the integrity of the pipeline the safety of the public and the environment, it is critical that land use planners, property and service designers, developers, owners and operators, construction organisations, etc. and the general public take into account the presence of the pipeline in their intended activities.

It is important that any planning, development or changes near the pipeline are advised to Viva Energy in the concept stages such that the work will not interfere with the pipeline and vice versa.

The work may require additional protection in the form of concrete slab cover, increasing the depth or varying the route of the pipeline. The cost of these changes would be borne by those initiating the work.

Various constraints are applied to ensure access is maintained, buildings are prevented, vegetation and addition of fill is restricted, power and telegraph poles, fencing and agricultural activities are controlled. These are detailed below.

Access to the pipeline

In order to maintain security and safe operation of the pipelines, regular patrol of the route is required under section 7.4 of AS2885.3-2012 in compliance with applicable pipelines legislation and as a condition of the pipeline licence.

To meet these requirements, the easement or pipeline route must be able to be accessed and traversed by pipeline personnel (and authorised contractors) at any time without delay.

Where gates are to be locked, access is usually achieved by adding a Viva Energy company padlock into the chain.

Note: Under section 117 of the Pipelines Act it is an offence to wilfully obstruct a person acting under the authority of a licensee in the lawful exercise of the licensee's powers in relation to the operation of a pipeline; or without the authority of a licensee, interfere with any works relating to the operation of a pipeline by the licensee. Penalties apply.

Prohibition of buildings near the pipeline

Under section 120 of the Pipelines Act 2005, a person must not construct a building so that any part of it is situated less than 3 metres from a point on the surface of the land whose position is vertically above a part of a pipeline below the surface unless the Minister has first consented to that construction. Penalties and demolition orders apply to contravention.

This clearance is to allow access for patrol and maintenance activities - in particular excavation of the pipeline. In practice, a clearance distance of 6.0 metres is more appropriate.

Vegetation on and near the pipeline

Vegetation is to be restricted to allow free passage along the pipeline route and to prevent root damage to the pipeline anti-corrosion coating. Accordingly, trees and shrubs are not to be planted on the easement and to prevent future damage to root systems during excavation for pipeline maintenance should not be planted closer than two-thirds of the mature height from the edge of the easement. Where no easement exists a minimum distance of 3.0 m but preferably 6.0 m either side of the pipeline should be substituted for easement.

Specifically, the following tree species are not to be planted within 6.0 m of the pipeline:

Cinnamomum (Camphor Laurel), Erythrina Species (Coral Trees), Eucalyptus Species (Gums, Stringy Barks, etc.), Ficus Species (Fig Trees), Grevillea Robusta (Silky Oak), Jacaranda Mimosifolia (Jacaranda Tree), Plantinus Species (Plane Trees), Populus Species (Poplar Tree), Salix Species (Willow Trees), Schinus Molle (Pepper Trees).

Addition of fill on or near the pipeline

It is preferred that fill is not added on or near the pipeline as this increased depth increases the cost of excavation and the poor stability of the fill increases the risk of cave-in during excavation. The depth of fill shall not exceed 1.0 m. If fill must be added, the depth and quality is to be advised prior to placement for agreement by Viva Energy Australia. Any landscaping shall be level within the easement or a minimum of 3.0 m (but preferably 6.0 m) either side of the pipeline to permit excavating equipment to operate without having to destroy the adjacent landscaping.

The addition of fill on or near the pipeline shall only be clean, preferably the same as the natural soil in that area and must not contain ash or chemicals - so as to not change the natural soil resistivity or affect the pipeline steel or anti-corrosion coating material.

Power and telegraph poles, fencing and agricultural activities

Proposed new or replacement power and telegraph poles (including strainer anchors and earth systems) and fencing across or along the easement or pipeline route are to be advised to Viva Energy Australia prior to commencement to prevent damage to the pipeline by pole hole augers or pole drivers. Poles are to be placed once the exact pipeline location has been marked by Viva Energy and the required minimum clearance of 3.0 m has been achieved. Fencing along the easement/pipeline route shall be a minimum of 3.0 m from the pipeline.

Agricultural activities such as deep ripping and the installation of drainage systems are not permitted on the pipeline easement or when no easement exists a minimum of 3.0 m (but preferably 6.0 m) either side of the pipeline. Such works adjacent are to be advised to Viva Energy prior to commencement to allow marking out the prohibited area.

Contact

Viva Energy Pipelines Coordinator – VIC

Name:	Matt Lynch
Phone:	M 0418 386 764 PH (03) 9391 6568
Email:	matthew.j.lynch@vivaenergy.com.au

Viva Energy Pipelines Maintenance Supervisor

Name:	David Kelly
Phone:	M 0418 386 762
Email:	d.kelly@vivaenergy.com.au

Creagh de Brabander
Pipelines Operations Manager
Viva Energy Australia Pty Ltd

W.A.G. Pipeline Proprietary Limited (ABN 73 004 784 310) is a subsidiary of Viva Energy Australia Pty Ltd

GHD

180 Lonsdale Street
Melbourne, Victoria 3000

T: (03) 8687 8000 F: (03) 8687 8111 E: melmail@ghd.com.au

© GHD 2016

This document is and shall remain the property of GHD. The document may only be used for the purpose for which it was commissioned and in accordance with the Terms of Engagement for the commission. Unauthorised use of this document in any form whatsoever is prohibited.

G:\31\34251\WP\254142.docx

Document Statusa

Revision	Author	Reviewer		Approved for Issue		
		Name	Signature	Name	Signature	Date
A	M.George	S.Rowland	S.Rowland*	S.Rowland	S.Rowland*	15/9/16
B	M.George	S.Rowland	S.Rowland*	S.Rowland	S.Rowland*	24/10/16

Disclaimer

This report: has been prepared by GHD for Department of Environment Land Water and Planning and may only be used and relied on by Department of Environment Land Water and Planning for the purpose agreed between GHD and the Department of Environment Land Water and Planning.

GHD otherwise disclaims responsibility to any person other than Department of Environment Land Water and Planning arising in connection with this report. GHD also excludes implied warranties and conditions, to the extent legally permissible.

The services undertaken by GHD in connection with preparing this report were limited to those specifically detailed in the report and are subject to the scope limitations set out in the report.

The opinions, conclusions and any recommendations in this report are based on conditions encountered and information reviewed at the date of preparation of the report. GHD has no responsibility or obligation to update this report to account for events or changes occurring subsequent to the date that the report was prepared.

GHD has prepared this report on the basis of information provided by Department of Environment Land Water and Planning and Stakeholders outlined in Section 1 who provided information to GHD which GHD has not independently verified or checked beyond the agreed scope of work. GHD does not accept liability in connection with such unverified information, including errors and omissions in the report which were caused by errors or omissions in that information.

www.ghd.com

